

Presented by

Andy Hebborn

Airbus, UK
Head of Landing Gear Systems



A380 Landing Gear and Systems

HAW Hamburg

5th June 2008

Lecture for RAeS, DGLR, VDI and HAW Hamburg

Download from:
<http://AeroLectures.de>



A380 Landing Gear & Systems – An Overview

Introduction



Description of Landing Gears and Associated Systems

- Development of Gears Layout
- Highlight new functions and technologies
- Overview of Systems Architectures and Equipment

A380 Landing Gear & Systems – An Overview

The Aircraft

The A380

- The A380 is a completely new, very high capacity, very long range commercial transport aircraft, powered by 4 RR Trent 900 or Engine Alliance GP7200 engines
- Standard A380-800 accommodates 555 Passengers in three-class long-range arrangement
- MTOW 569 tonnes, MLW 391 tonnes
- First flight 27 April 2005
- Entry into service Oct 2007, with Singapore Airlines
- Delivery schedule for 2008: 13 A/C to Singapore, Qantas and Emirates



A380 Landing Gear Systems – An Overview

Major Components and Systems

- ▶ ATA Chapter 32 Landing Gear Systems
- ▶ Gears
 - Nose Landing Gear (2 Wheels)
 - Body Landing Gear x2 (Bogie Type, 6 Wheels - 4 Braked)
 - Wing Landing Gear x2 (Bogie Type, 4 Wheels - 4 Braked)
- ▶ Extension/Retraction System
- ▶ Braking Control System
- ▶ Steering Control System
 - Nose Wheel Steering
 - Body Wheel Steering
- ▶ Wheels, Tyres and Brakes (16 Braked Wheels)
- ▶ Monitoring Systems
 - Tyre Pressure Indication System
 - Brake Temperature Monitoring System
 - Oleo Pressure Monitoring System

A380 Landing Gear & Systems – An Overview

Evolution of Main Landing Gear Configuration

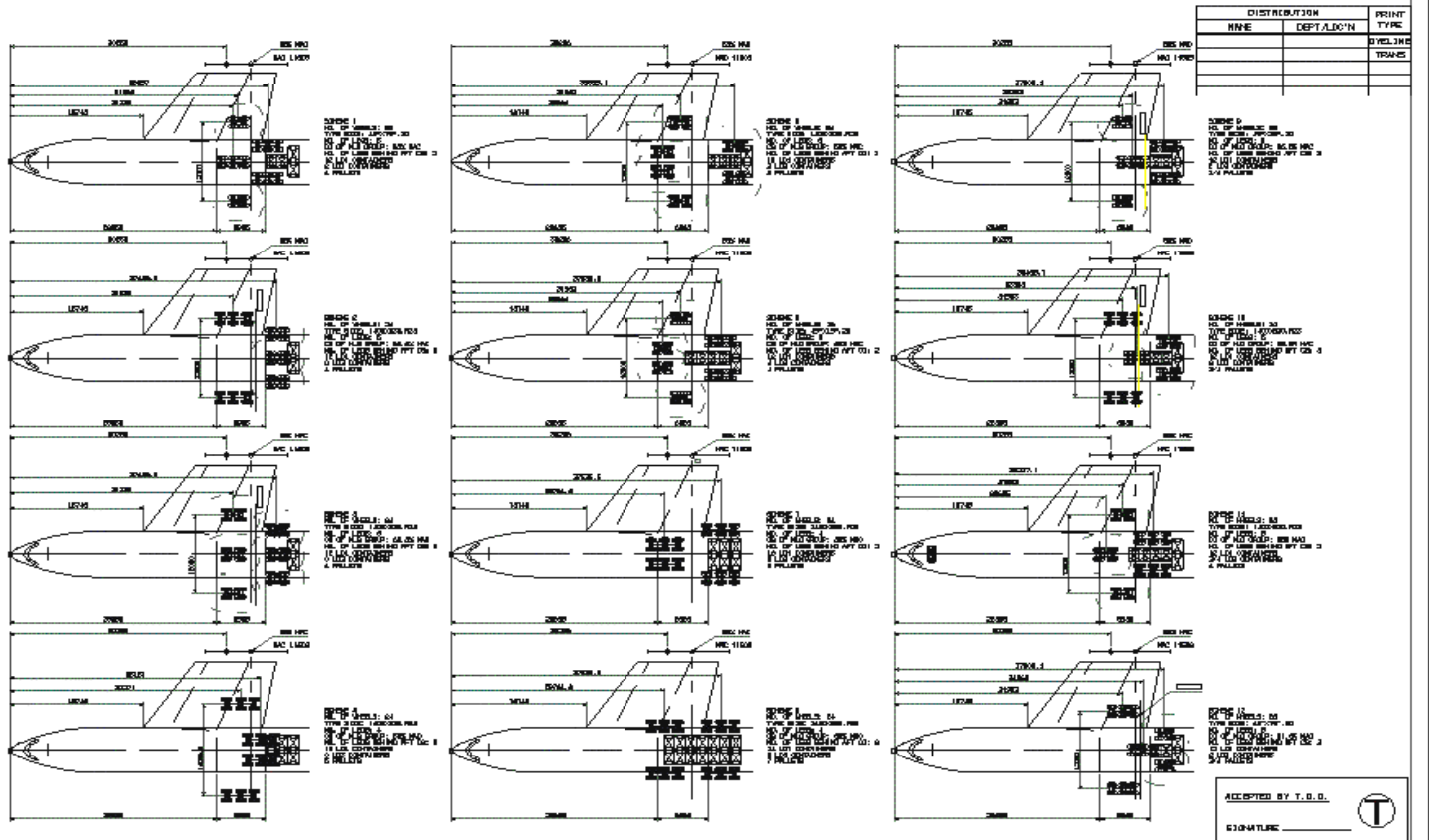

A380 Landing Gear Configuration Starting Point – 38 Alternatives

FULL	REV	PREP	ISSUE LETTER	DATE	REVISIONS

COMPUTER GENERATED DRAWING
UNING - PARTIAL VARI 7
NO MANUAL ALTERATION

BY	DATE	BY	DATE
H. WHITE		H. WHITE	

TITLE: AIRBUS
FIRST NAME:



A380 Landing Gear & Systems – An Overview

Evolution of Main Landing Gear Configuration

First Down Selection:

2 Family Concepts for the gear and airframe

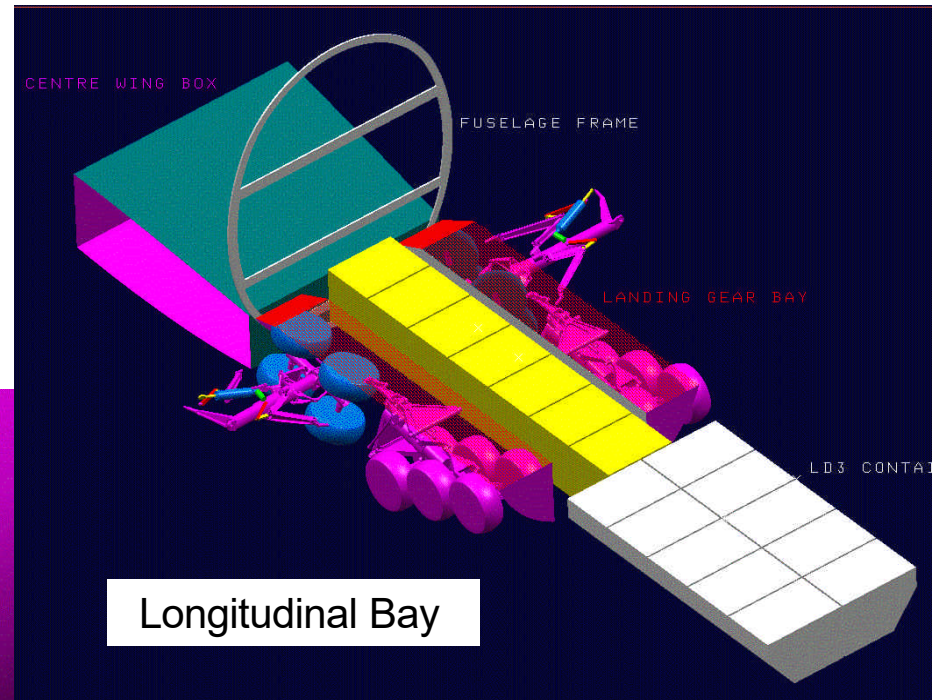
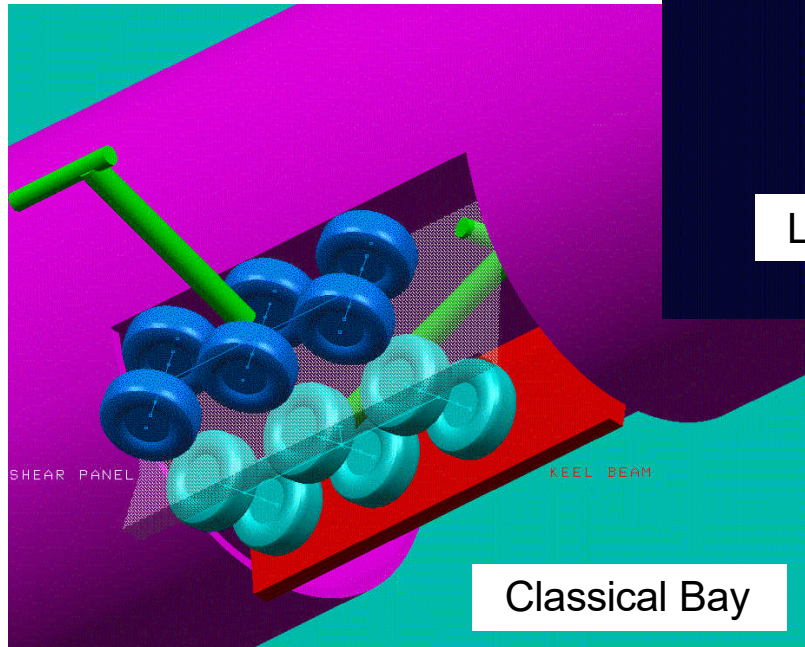

A380 Landing Gear & Systems – An Overview

Evolution of Main Landing Gear Configuration

Second Down Selection:

- Family Concept Selected
- Kinematic Options traded

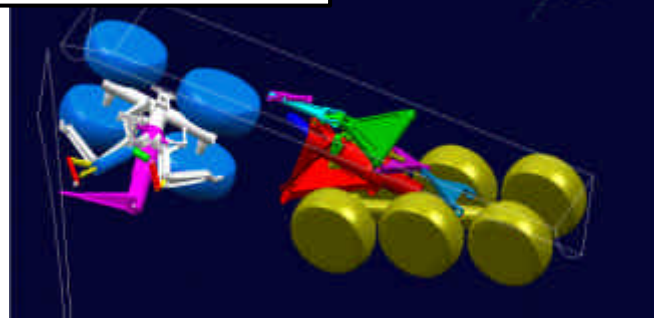
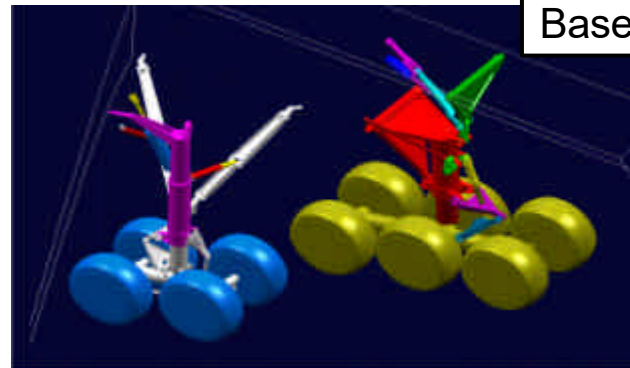
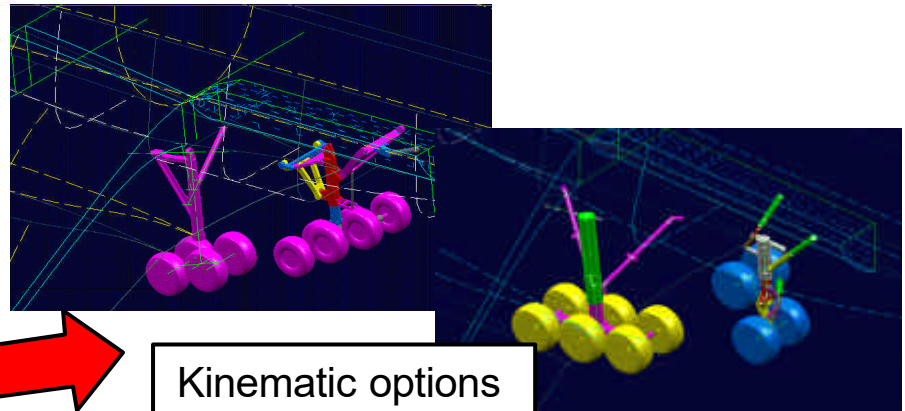
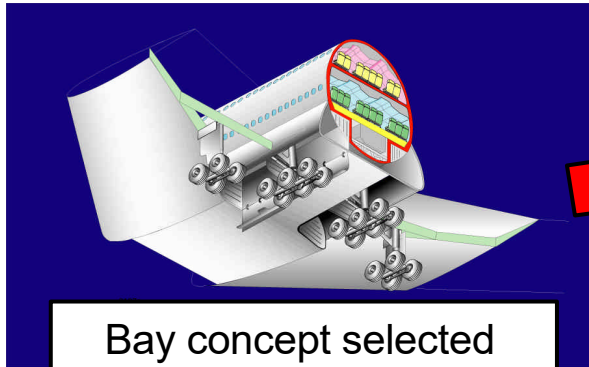

A380 Landing Gear & Systems – An Overview

Evolution of Main Landing Gear Configuration

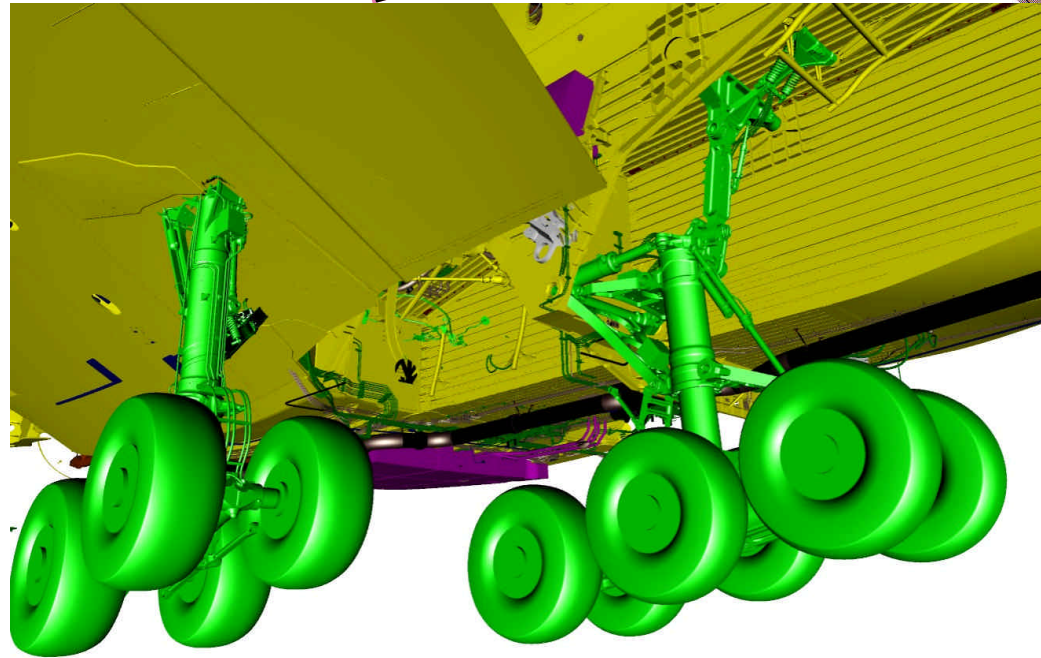
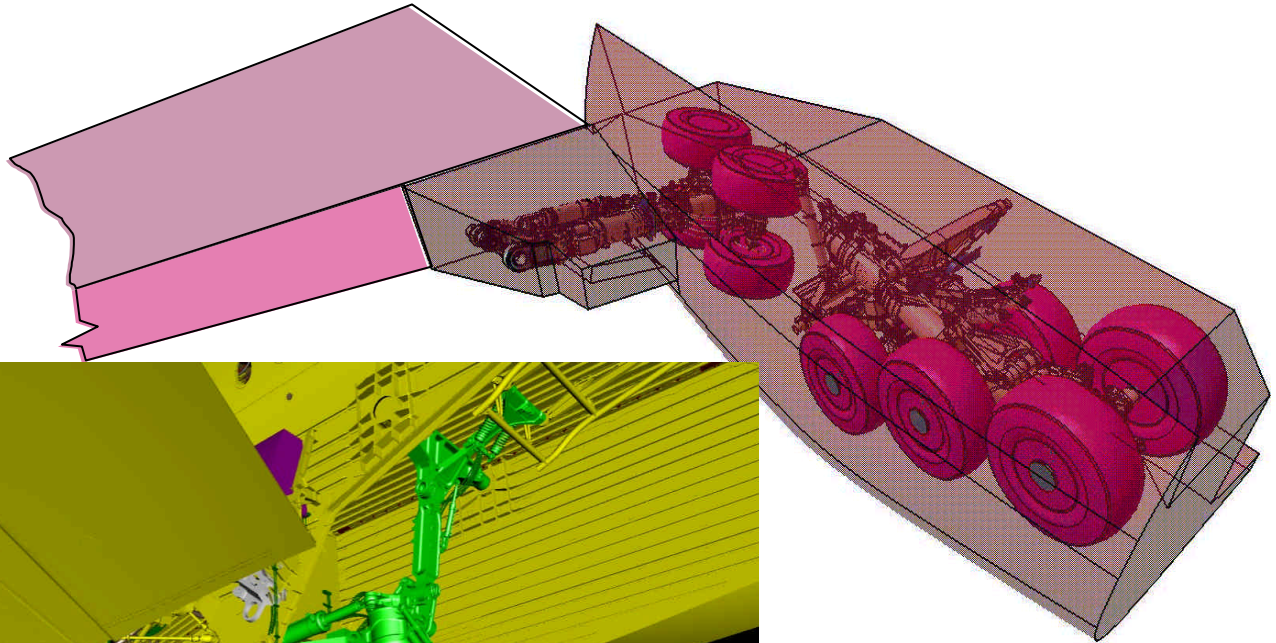

Main Gear Group:
Installation in Wing
& Fuselage

A380 Landing Gear Systems – An Overview

Evolution of Gears Configuration

- **Landing Gear Configuration – Basic Requirements**

- ▶ one concept philosophy for all aircraft variants
- ▶ each variant capable of optimization
- ▶ concept capable of development to significantly higher design weights
- ▶ ACNs no worse than existing large aircraft
- ▶ Nose gear to be compatible with towbarless towing

- **Manoeuvring on ICAO code E and FAA group V airports**

- ▶ 45m wide runways and 23m taxiways
- ▶ U-turn on 60m wide runway possible

- **Capable of growth beyond current a/c definitions**

- ▶ 2 wheel or 4 wheel CLG installation possible

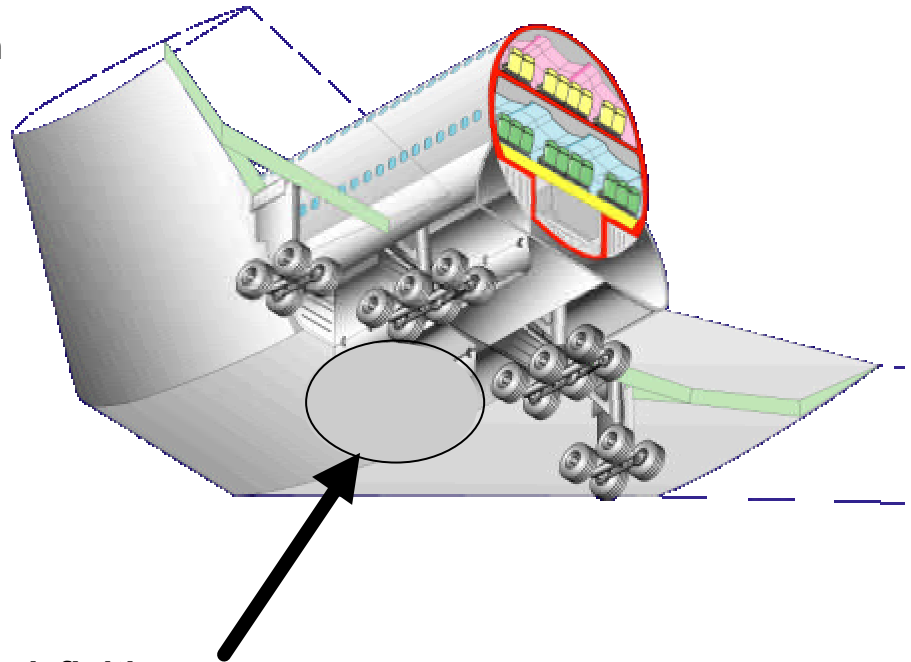

A380 Landing Gear Systems – An Overview

Wing Landing Gear

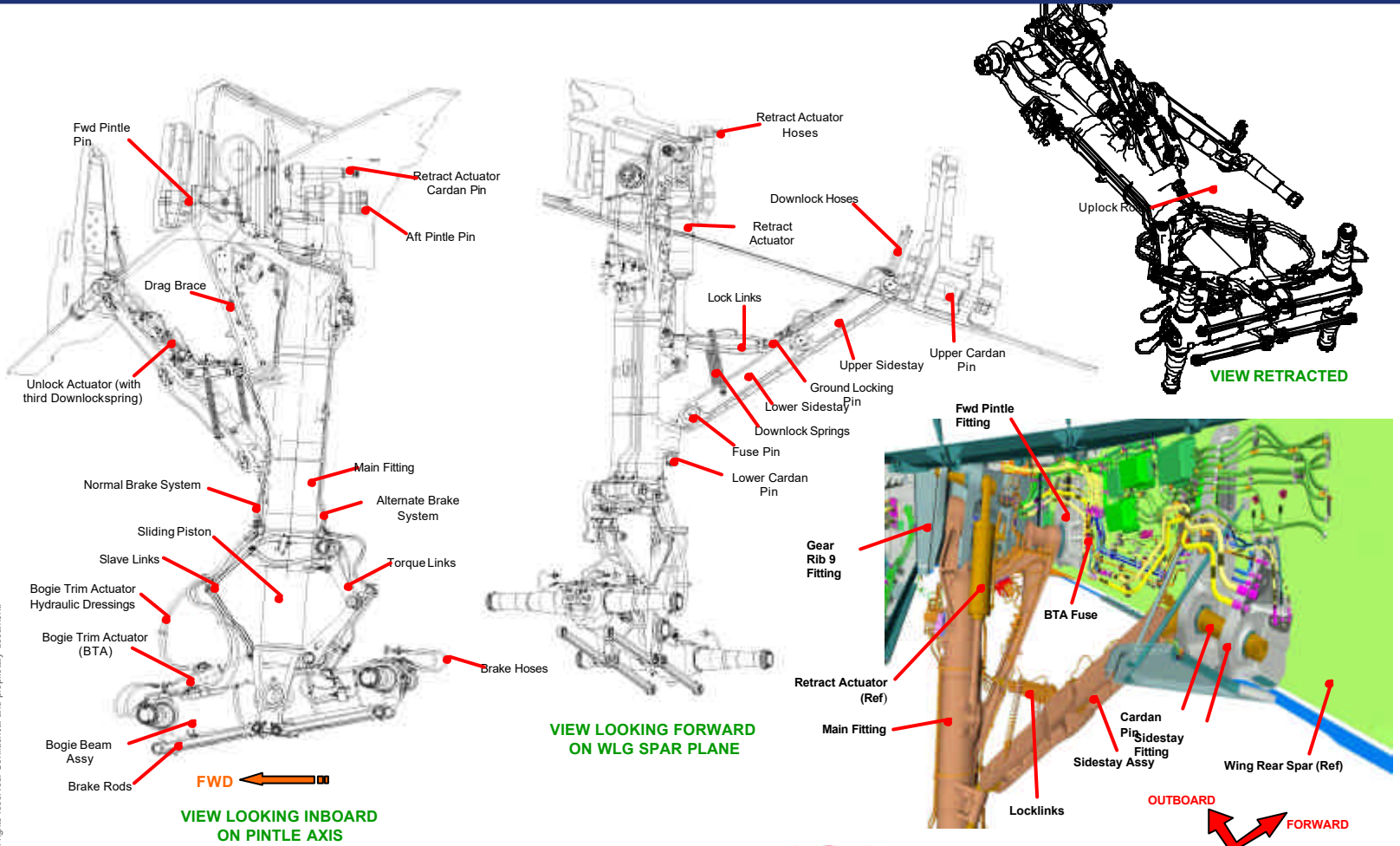

© AIRBUS UK LTD. All rights reserved. Confidential and proprietary document.

A380 Landing Gear & Systems – An Overview

Body Landing Gear

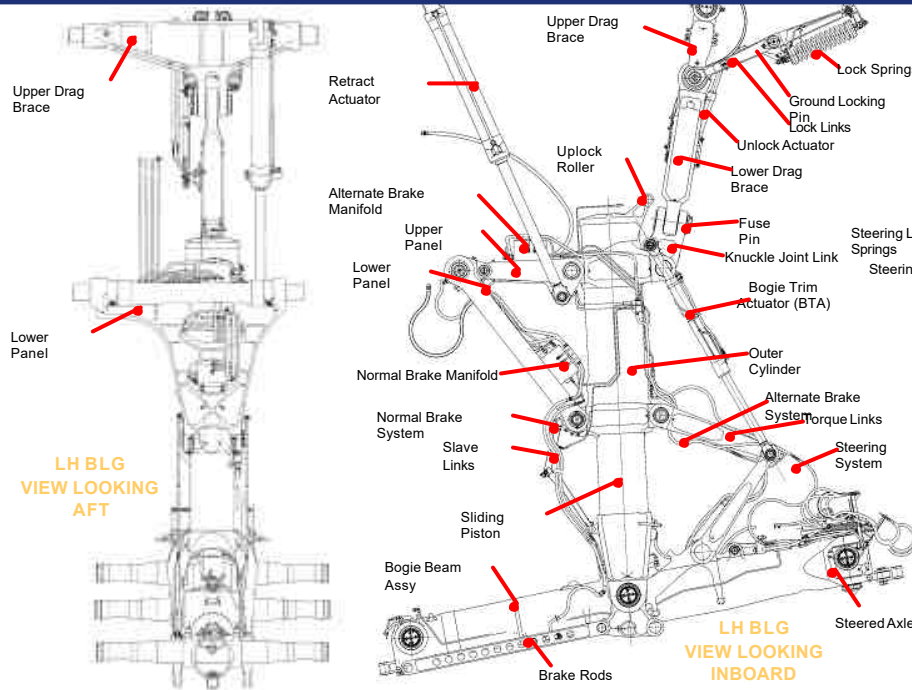

LH BLG
VIEW LOOKING
AFT

LH BLG
VIEW LOOKING
INBOARD

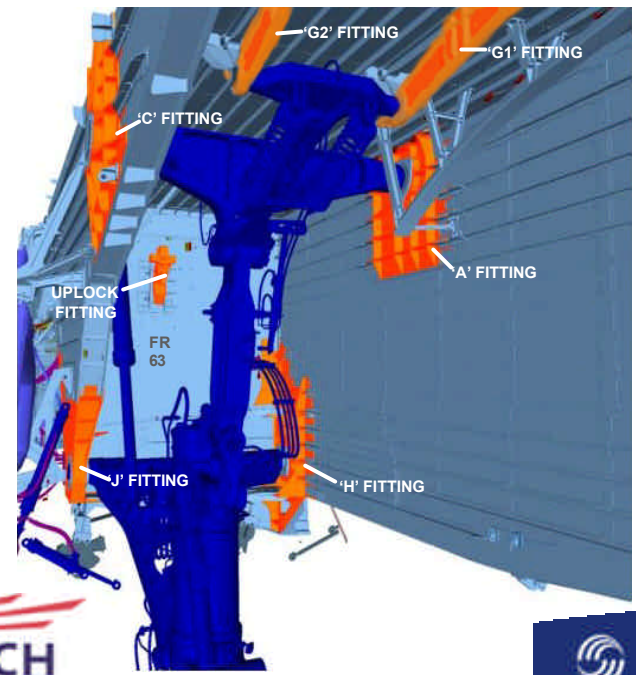
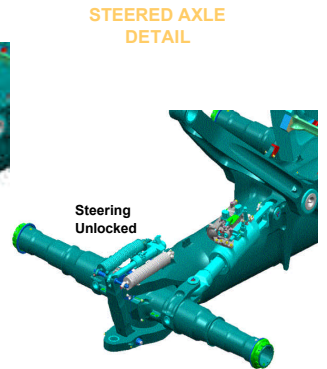
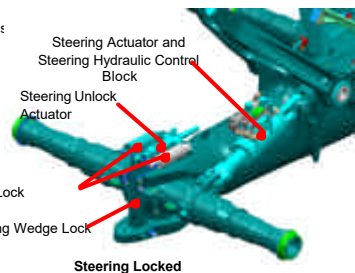
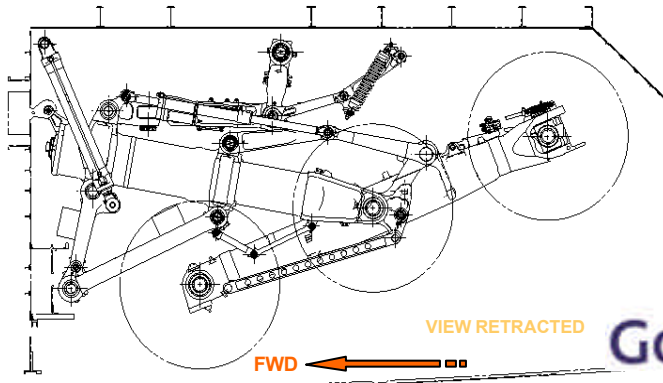

A380 Landing Gear & Systems – An Overview

Nose Landing Gear

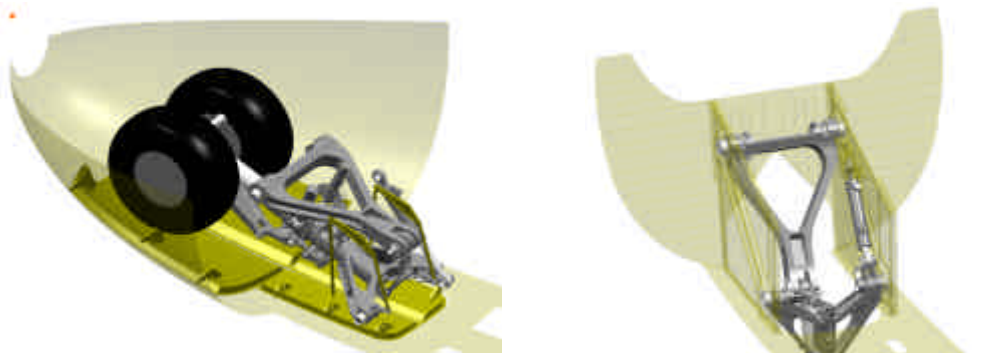

Nose Wheel Steering (NWS):
 Towing Angle is +/- 60°
 Hydraulic Steering Angle is +/- 70°
 Mechanical Stop Angle is +/- 75°

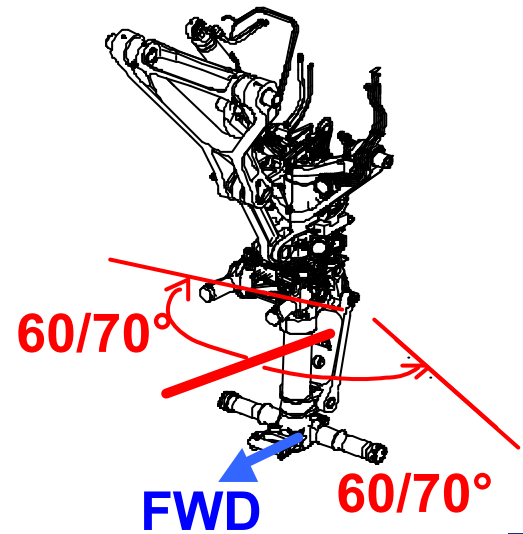
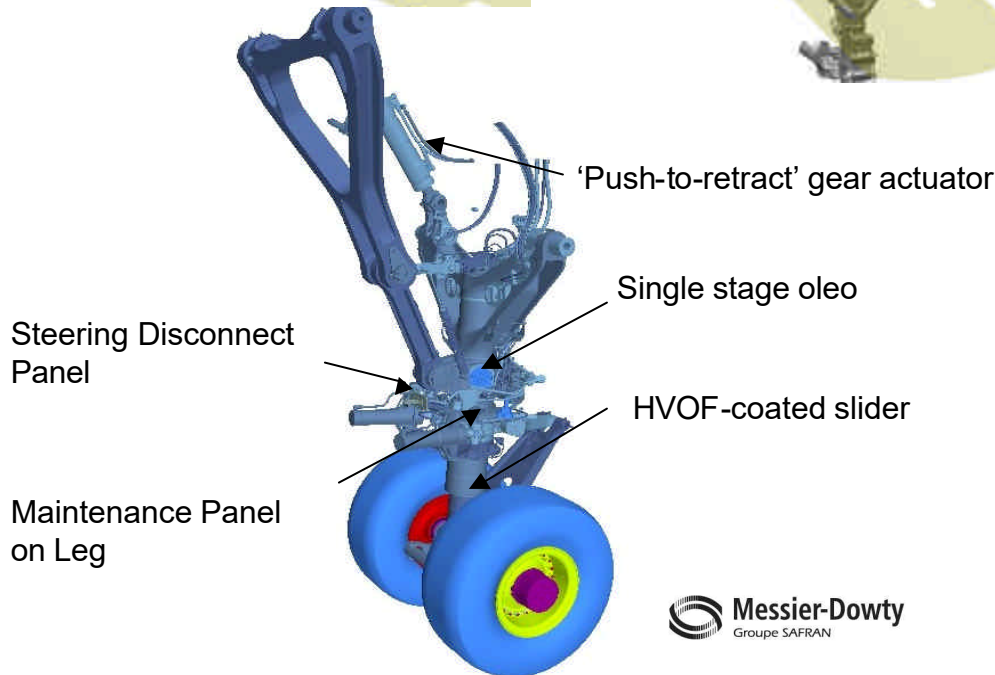

A380 Landing Gear & Systems – An Overview

Landing Gear Structure

Weight / Cost / Size / Timescale Trade-offs

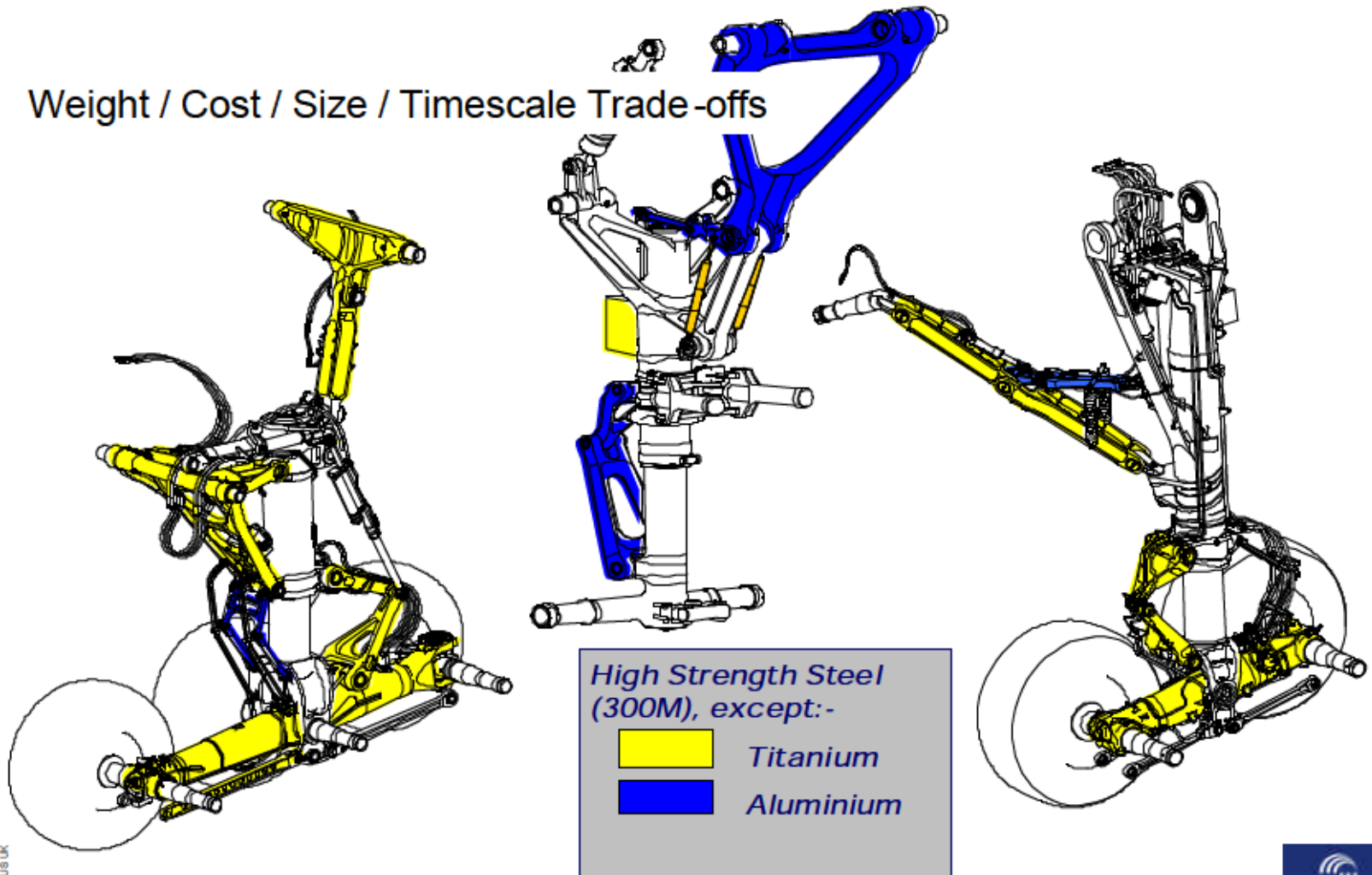

A380 Landing Gear Systems – An Overview

Gears Retraction Animation

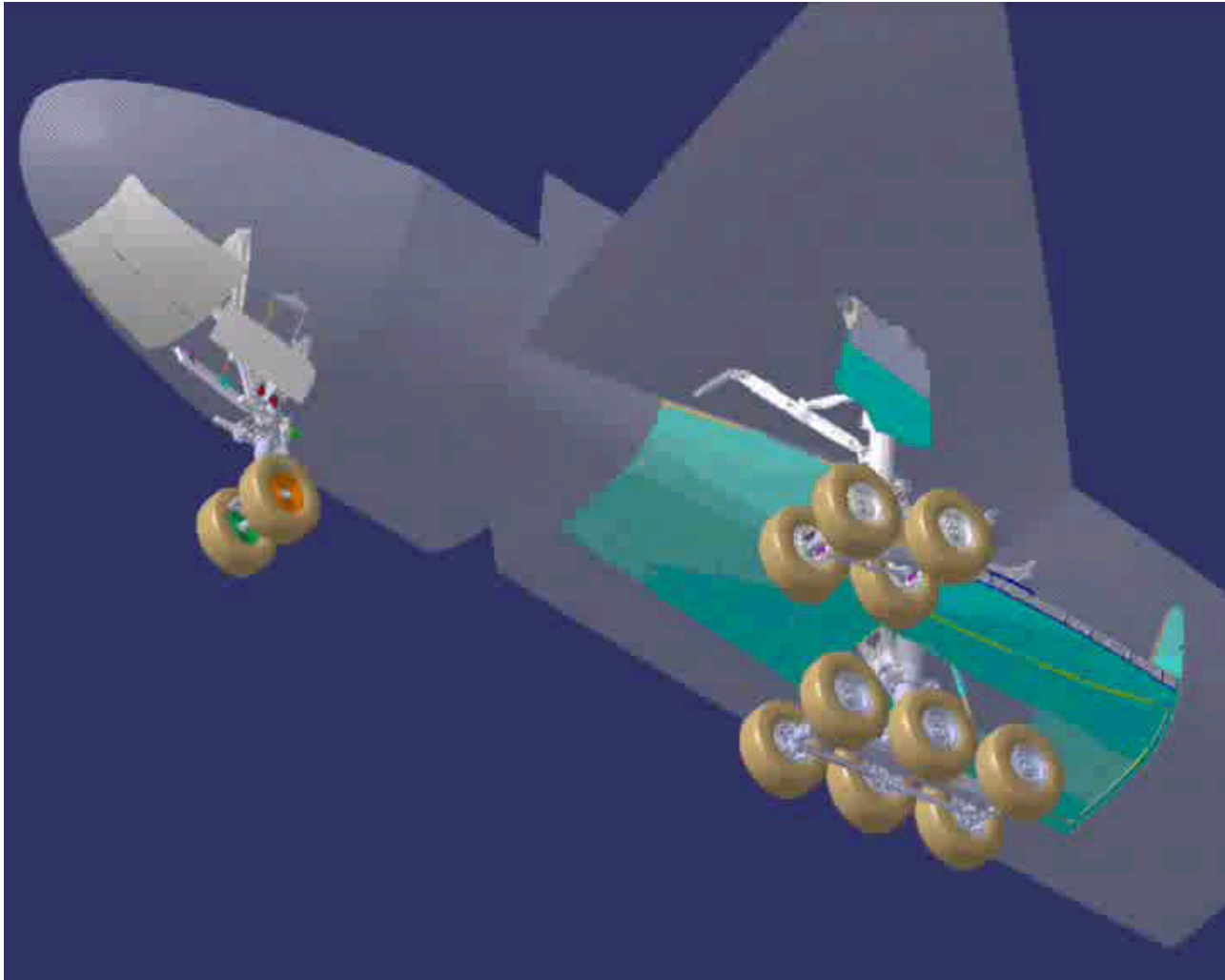

A380 Landing Gear Systems – An Overview

Main Wheel, Tyre and Brake

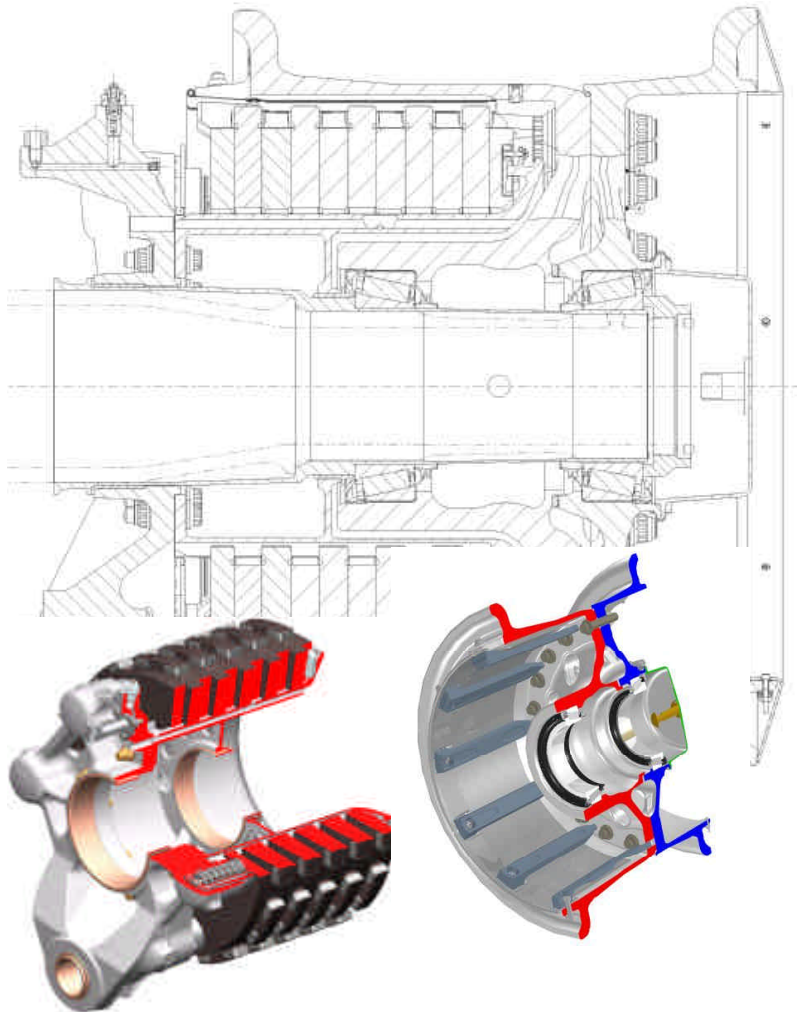

Honeywell Wheel & Brake:

Braked Wheel

- Deep Cavity A-Frame
- 2014-T6 Aluminium Alloy
- 23 inch rim size
- 11 Vent Holes
- 11 Drive keys
- 22 Inconel Tie Bolts
- Segmented Heat-shield
- Stainless Steel Axle Sleeve

• Non-Braked Wheel

- Symmetric A-Frame

• Brake

- 5 Rotor Carbenix® 4000 heat-sink
- 1.59inch wear pin
- 23 spline titanium torque tube
- Aluminium 7050 piston housing
- 6 x Ø1.805" pistons (split-ball adjuster)
- Integral Lug and steel torque pin

• Bridgestone Tyre

- 1400x530 R23 40PR Lightweight Radial

A380 Landing Gear Systems – An Overview

Nose Wheel and Tyre

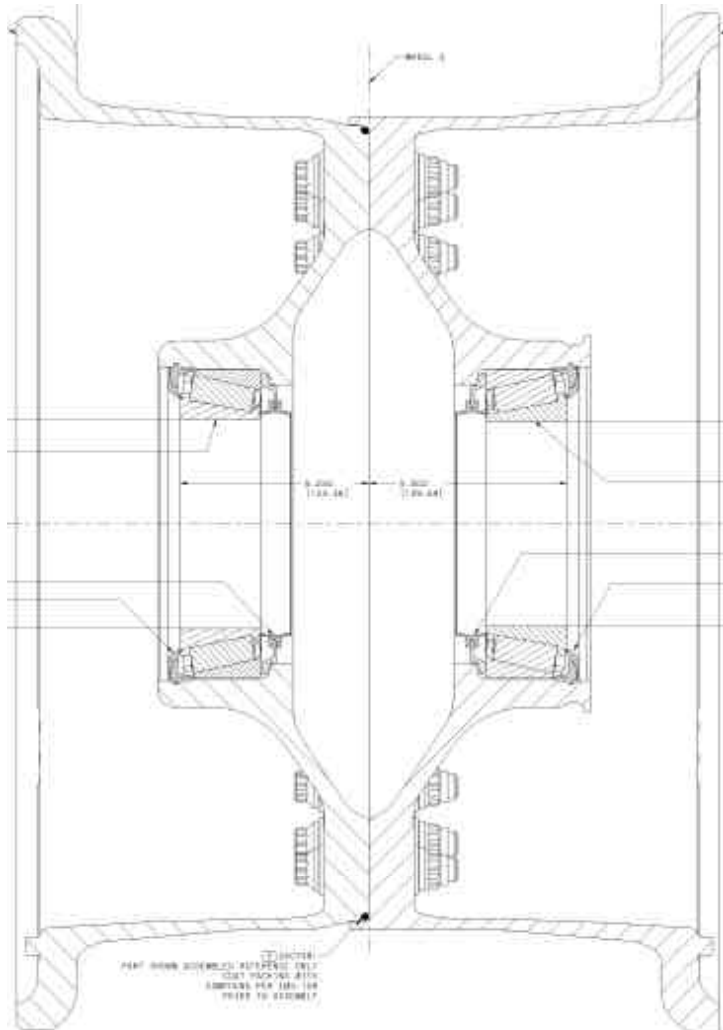

• Honeywell Wheel

• Wheel

- Symmetric A-Frame
- 2014-T6 Aluminium Alloy
- 22 inch rim size
- Iconel Tie Bolts
- Light-weight Aluminium Axle Sleeve

• Bridgestone Tyre

- 1270x455 R22 32PR Lightweight Radial

A380 Landing Gear Systems – An Overview

Power Systems Architecture

- **Hydraulic architecture :**

- ▶ 5000 psi
- ▶ 2 A/C circuit (Green & Yellow)
- ▶ Segregation Between Green and Yellow :
 - **BLGs ATA32 function on Yellow circuit only**
 - **WLGs & NLG ATA32 function on Green circuit only**
- ▶ All hydraulic back-up functions ensured by local hydraulic generation system (LEHGS) owned by the function system

- **Electrical Architecture :**

- ▶ AC : 115V Variable frequency
- ▶ DC: 28V with no power transients
 - 2 segregated Normal DC : DC1 & DC2
 - 1 Emergency DC : DC essential
 - 1 DC Service Bus

A380 Landing Gear Systems – An Overview

Local Hydraulic Power Generation System

- Redundancy of hydraulic power for Braking and Nose Wheel Steering provided by LEHGS

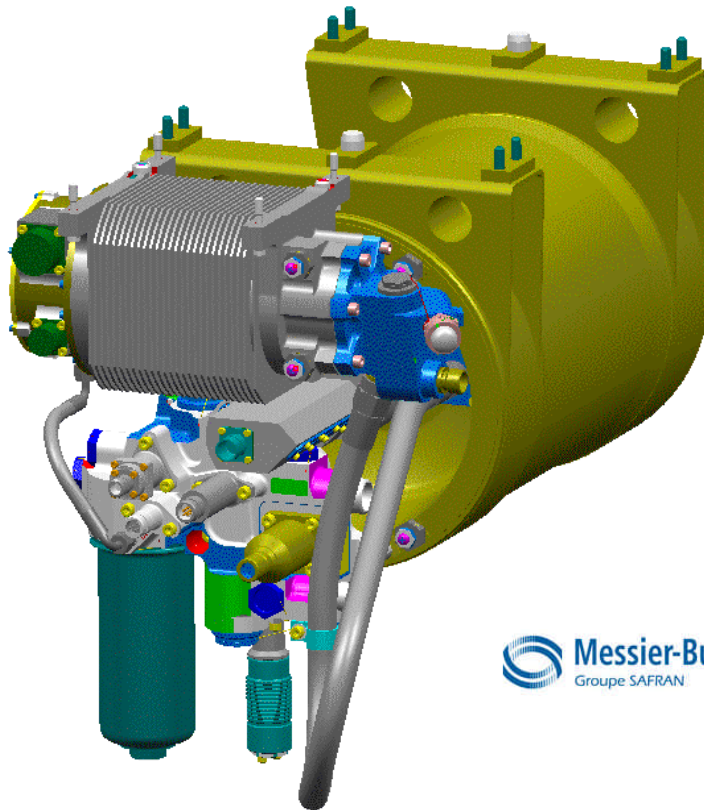

- Features:
 - ▶ Re-pressurises the HP accumulators to 350 bar throughout the flight
 - ▶ Low pressure reservoir with LVDT for level sensing and visual indicator
 - ▶ Electric motor-pump
 - ▶ Incorporates health monitoring (fluid and motor temperature sensing, filter clog detection)



A380 Landing Gear Systems – An Overview

System Avionics Architecture

1) Normal ATA32 functions controlled by shared avionics units for all systems

▶ Core Processor Input Output Module (Integrated Modular Avionics)

CPIOM-G (IMA): All ATA32 System functions

- Control functions and indication management
- Central monitoring functions (BITE)
- Main interfaces to other A/C systems

▶ Remote Data Concentrator

Landing Gear RDCs : Extension/Retraction (LGERs) and Monitoring (LGMS)

- Specific Systems sensors Acquisitions
- Ext/Ret Valves and Actuators second order control
- Local monitoring

Interface RDCs : Braking and Steering (BSCS)

- A/SKID and pressure control loop function
- Specific Systems sensors Acquisitions
- Local monitoring

2) Emergency ATA32 functions controlled by specific analogue units, independent of IMA and AFDX avionics technology

▶ **Brake Control : Emergency Brake Control (EBCU)**

▶ **Ext/Ret Free Fall : Free-Fall Control (FFCM)**

A380 Landing Gear Systems – An Overview

Oleo Pressure Monitoring System

- Oleo pressure is monitored simultaneously on all landing gear shock absorbers and any warning is passed on to the Flight Warning System.
- Prevents departure with mis-serviced Landing Gear
- Accurate Check - performed once per flight, after gear extension
- Gross Check - continuous monitoring
- Combined Pressure and Temperature sensor mounted on each Shock Absorber

OPMS is designed to:

- Provide a warning when one or more L/G oleo pressure is outside defined limits.
- Provide a warning when there is an OPMS equipment failure.
- Provide L/G oleo pressure status to the flight and maintenance crew.
- Provide other aircraft systems with L/G oleo pressure status & equipment information via AFDX.
- **OPMS removes the need for carrying out pre-flight oleo pressure checks by the maintenance crew.**

A380 Landing Gear Systems – An Overview

Brake Temperature Monitoring System

BTMS (Brake Temperature Monitoring System) :

- Prevents take-off with a hot brake
- Prevent landing gear retraction with a hot brake
- Monitors for residual braking due to a dragging brake

Equipment:

Brake Temperature Compensation Module

Brake Temperature Sensor located next to the brake heat pack.



A380 Landing Gear Systems – An Overview

Tyre Pressure Monitoring System (TPIS)

Tyre pressures are monitored simultaneously on all wheels and any warning is passed on to the Flight Warning System.

TPIS is designed to:

Provide other aircraft systems with tyre pressures & equipment status information.

Provide tyre pressure information to the flight and maintenance crew.

Provide an alert when the pressure in one or more tyres is outside defined limits.

Provide an alert when the differential pressure between any two tyres on the same axle differs by an amount beyond defined limits.

TPIS can be used to carry out daily tyre pressure checks.

A380 Landing Gear Systems – An Overview

Tyre Pressure Monitoring System (TPIS)

Depending on the flight phase, a warning will be triggered if a tyre pressure is detected below a given percentage of the nominal tyre pressure (for 5 seconds continuously).

Likewise, a warning will be triggered if a **differential** pressure above a given percentage is detected across tyres on the same axle (measured from the tyre with the higher pressure).

A **'TYRE PRESS LO'** message will be displayed on the E/WD if a Low or Differential tyre pressure condition is triggered.

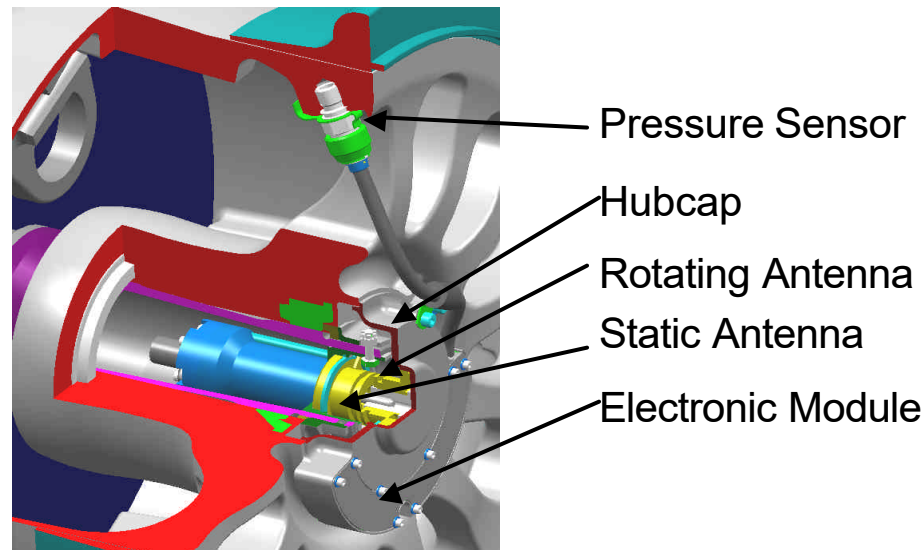

A380 Landing Gear Systems – An Overview

Steering Control System

Steering is mainly effected on the NLG Wheel Pair by classic push-pull design (Nose Wheel Steering)

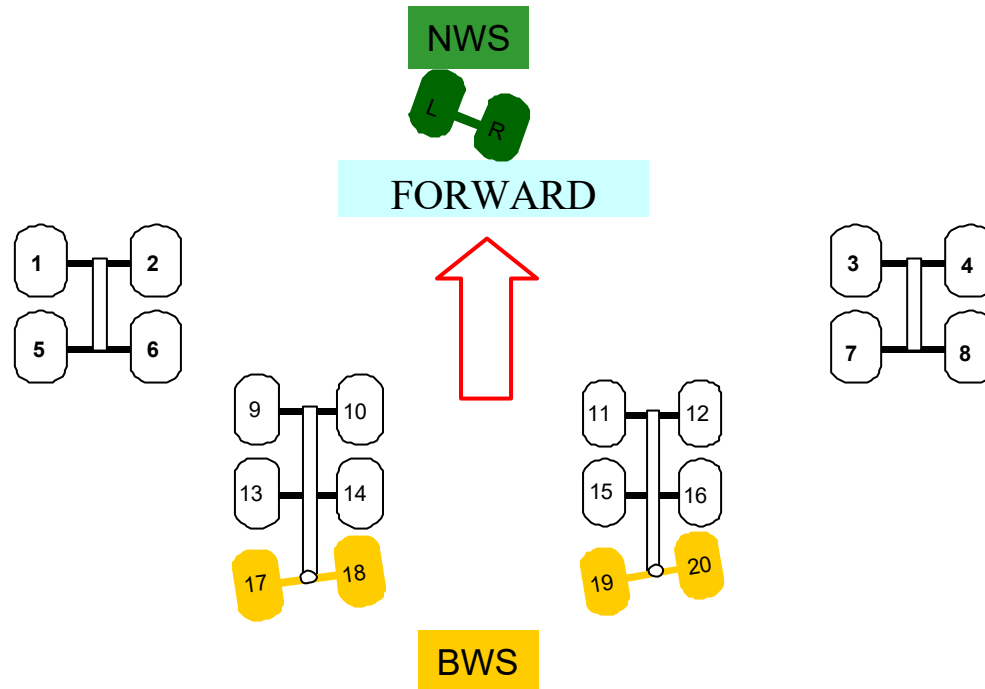

Aft Axle of BLG is steerable to ensure better manoeuvrability for small radius turn (Body Wheel Steering)

A380 Landing Gear Systems – An Overview

Steering Control System Architecture

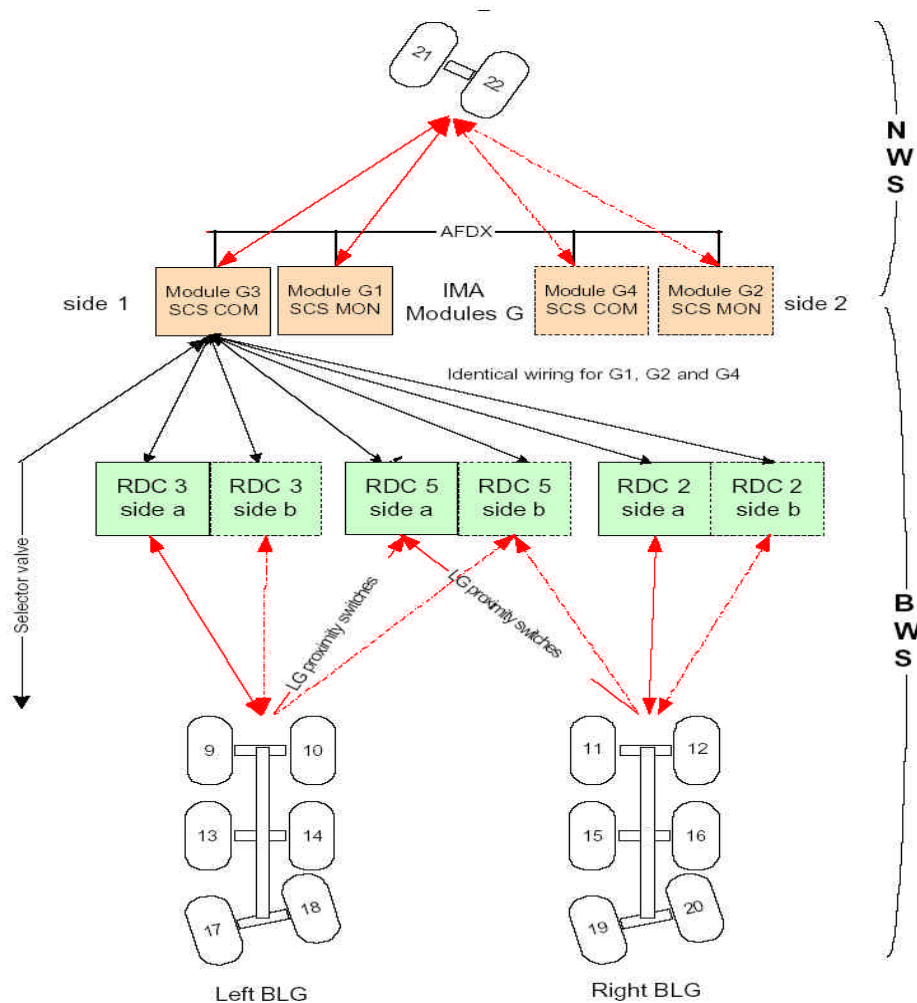

A380 Landing Gear Systems – An Overview

NWS Control – Gear Mounted Components

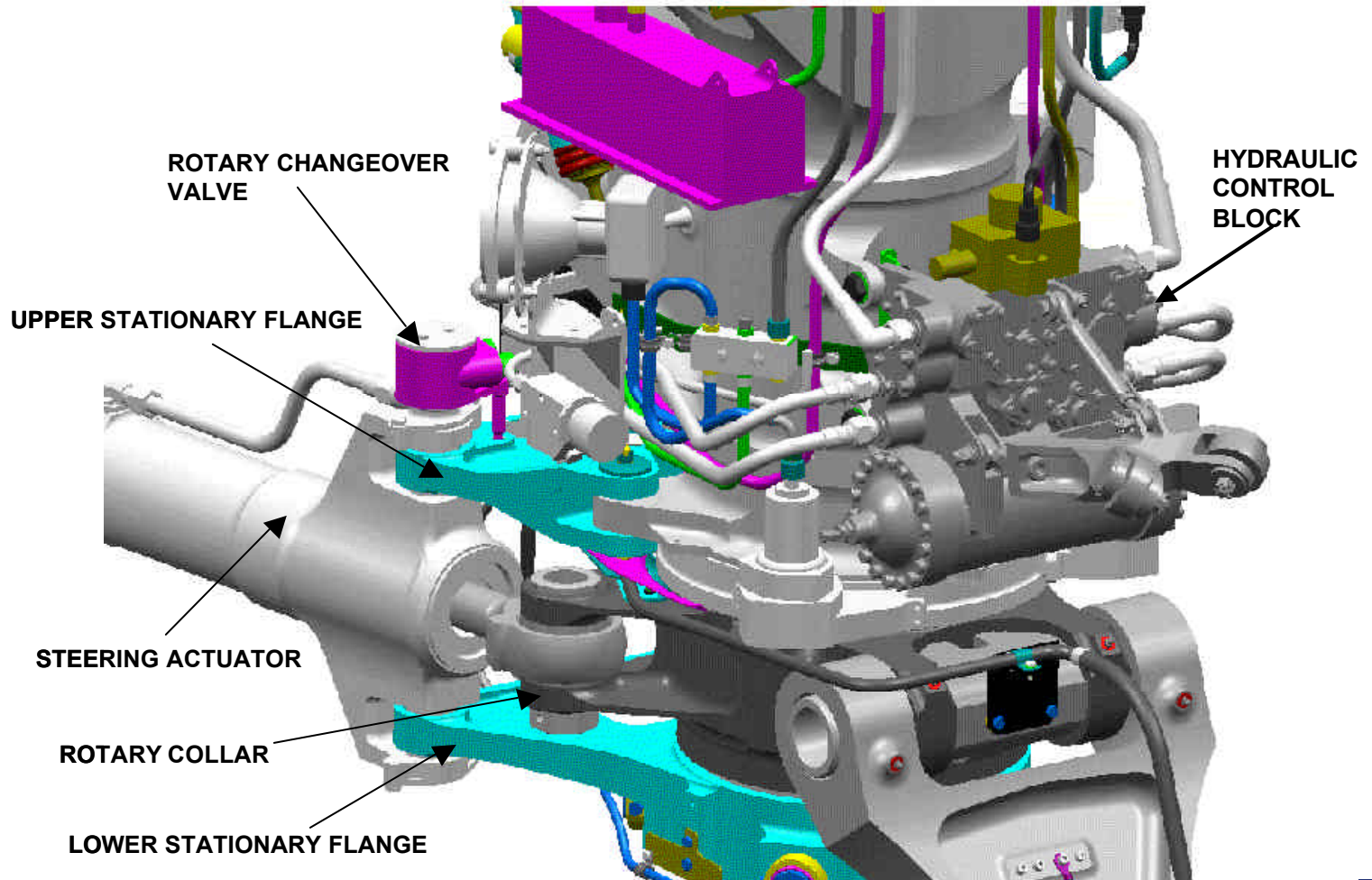

A380 Landing Gear Systems – An Overview

Body Wheel Steering – Gear Mounted Components

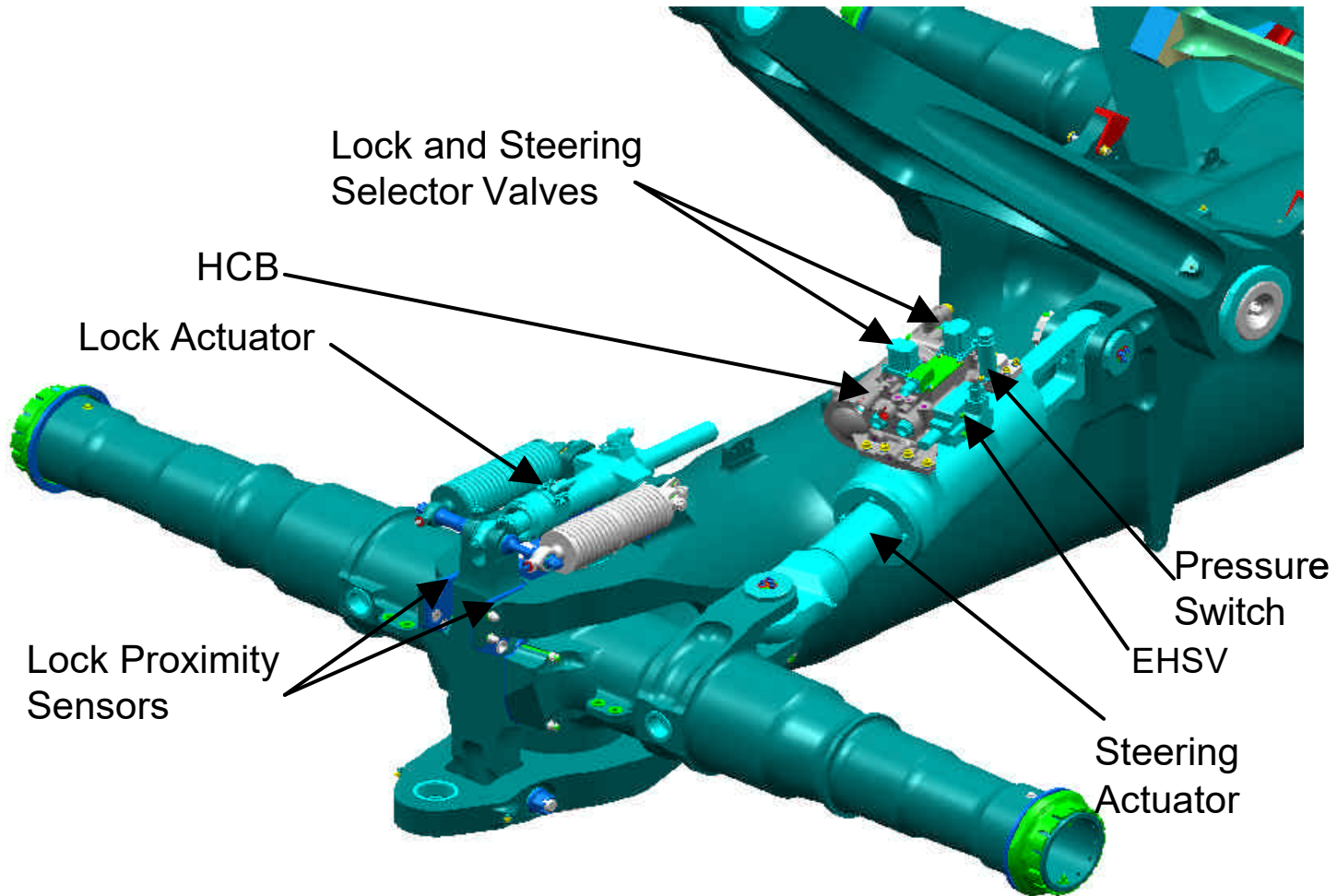

A380 Landing Gear Systems – An Overview

Brake Control System

NORMAL / ALTN BRAKING

- Body Landing Gear (BLG) & Wing Landing Gear (WLG) attached to separate hydraulic systems
 - ▶ BLG – Yellow, WLG – Green
 - ▶ Single Cavity Brakes
 - ▶ Servo Valve per Wheel Pair
- LEHGS (Local electro-hydraulic generation supply)
 - ▶ Electric motor driven pump supply Alternate hydraulics

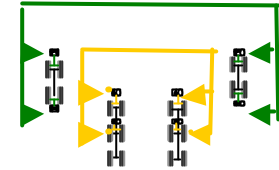

AUTO-BRAKE

- Autobrake function available in Normal & Alternate Braking mode
- Comfortable & symmetric disconnect
- Provision for Brake to Vacate function
 - ▶ Adapts deceleration rates to runway exits



A380 Landing Gear Systems – An Overview

Brake Control System

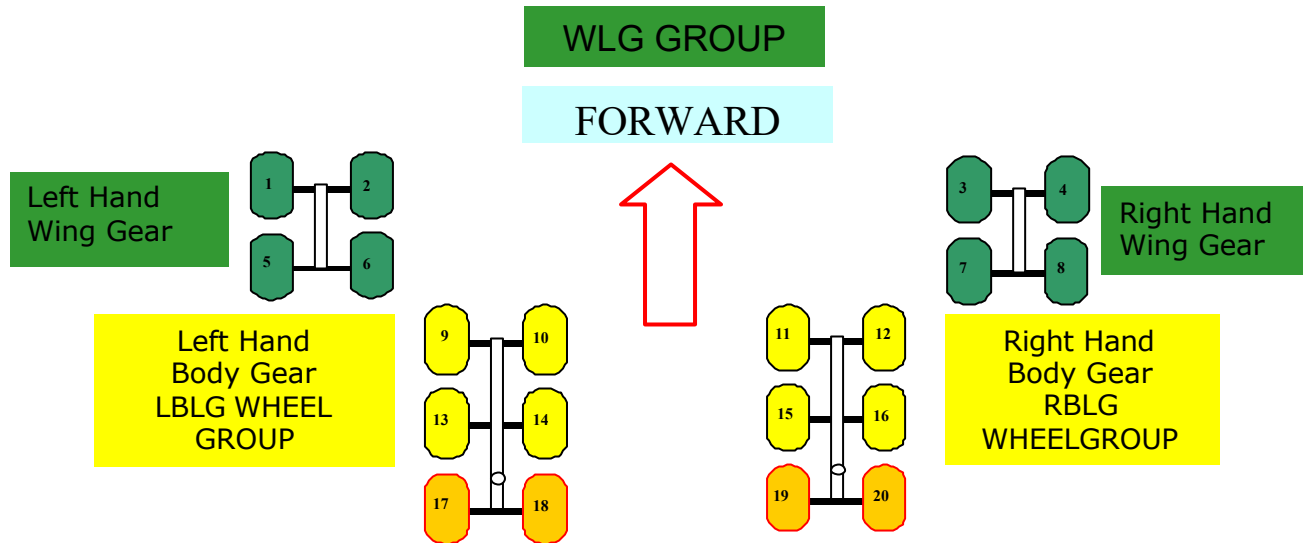

The Braking System architecture is divided into three groups linked to the three wheel groups :

- > WLG (8 wheel braked)
- > BLG (8 wheel braked- aft axle wheels not braked)

A380 Landing Gear Systems – An Overview

Brake Control System Architecture

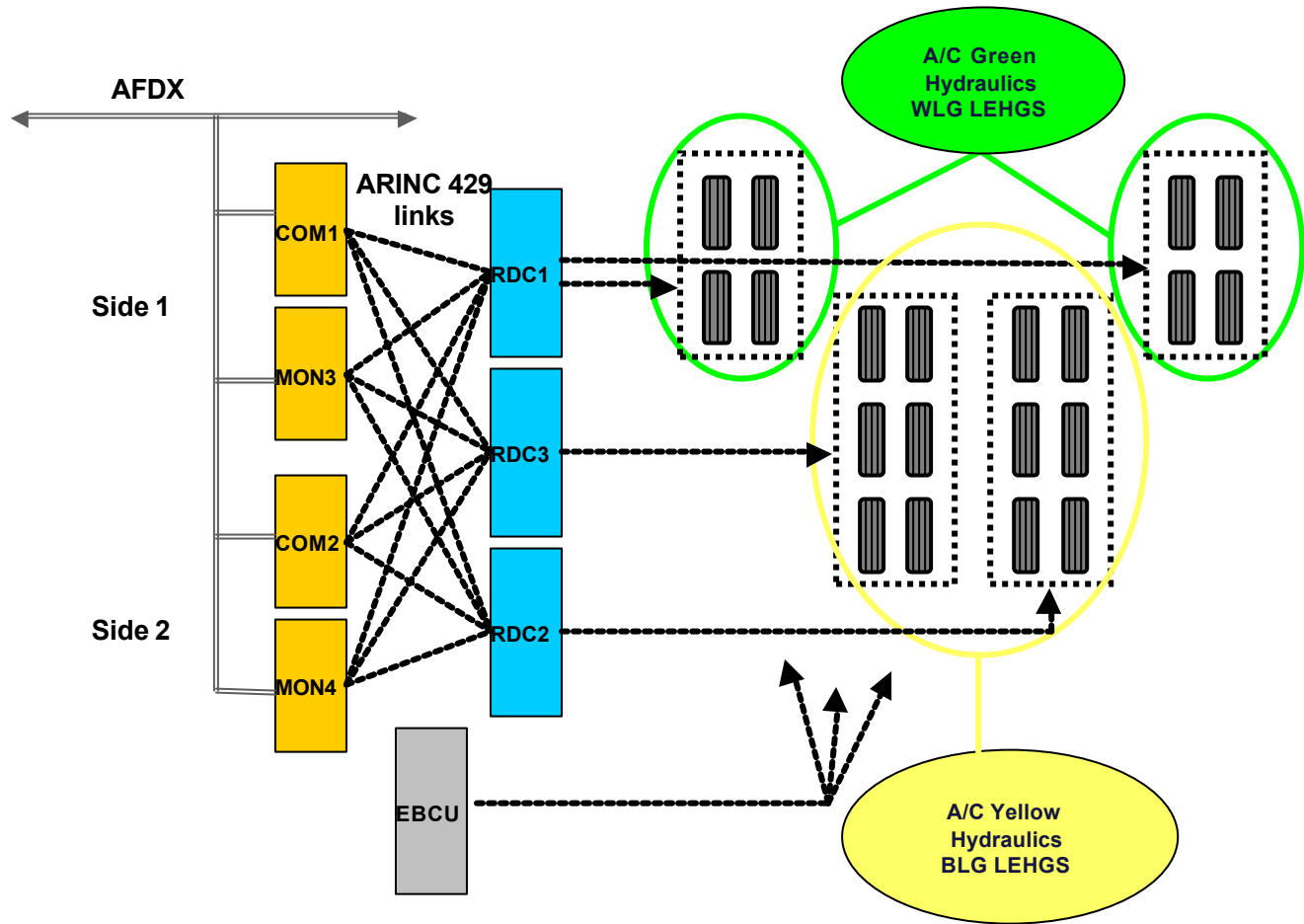

A380 Landing Gear Systems – An Overview

Brake Control System – Braking Modes

Braking Modes available per wheel group.

BRAKING	HYDRAULICS	CONTROL UNIT	ACTIVATION	FUNCTIONS
NORMAL	<ul style="list-style-type: none"> •YELLOW – BLG •GREEN – WLG 	IMA	<ul style="list-style-type: none"> •AUTOBRAKE •PEDALS 	<ul style="list-style-type: none"> •ANTI-SKID •PEDALS •AUTOBRAKE
ALTERNATE (WITH ANTI-SKID)	<ul style="list-style-type: none"> •LEHGS + ACCU 	IMA	<ul style="list-style-type: none"> •AUTOBRAKE •PEDALS 	<ul style="list-style-type: none"> •ANTI-SKID •PEDALS •AUTOBRAKE
ALTERNATE EMERGENCY	<ul style="list-style-type: none"> •LEHGS + ACCU Or •ACCU 	IMA	<ul style="list-style-type: none"> •PEDALS 	<ul style="list-style-type: none"> •NO ANTI-SKID •PEDALS with limited pressure
EMERGENCY (Same as above, but with EBCU control)	<ul style="list-style-type: none"> •LEHGS + ACCU Or •ACCU 	EBCU	<ul style="list-style-type: none"> •PEDALS 	<ul style="list-style-type: none"> •NO ANTISKID •PEDALS with limited pressure
ULTIMATE	<ul style="list-style-type: none"> •LEHGS + ACCU Or •ACCU 	EBCU	<ul style="list-style-type: none"> •PARK SWITCH ONLY 	<ul style="list-style-type: none"> •BRAKING ON ALL WHEELS
PARK	<ul style="list-style-type: none"> •NORMAL Or •LEHGS + ACCU 	-	<ul style="list-style-type: none"> •PARK SWITCH ONLY 	<ul style="list-style-type: none"> •BRAKING ON BLG ONLY

A380 Landing Gear & Systems – An Overview

Extension/Retraction System

The Landing Gear Extension and Retraction System is made up of three sub-systems:

The Normal System:

Landing Gear Control and Indication System (LGCIS) Side 1 and 2, implemented in IMA

Nose and Wing Landing Gear and Doors - Green Hydraulic System

Body Landing Gear and Doors - Yellow Hydraulic System

An Independent Freefall System for Emergency operation

Independent of IMA

Dedicated uplock electrical actuators and valves

Uses dissimilar technologies where possible to avoid common-mode failures

Uses different wiring routes

An Auxiliary Ground Door Opening System

Allows on-ground access to each landing gear bay for maintenance purposes

Electrically operated and controlled from GDO Panels

A380 Landing Gear & Systems – An Overview

Extension/Retraction System Equipment

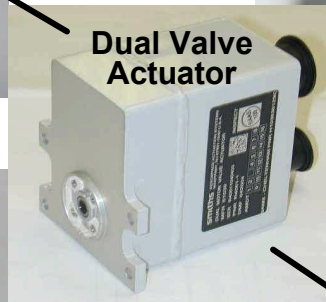
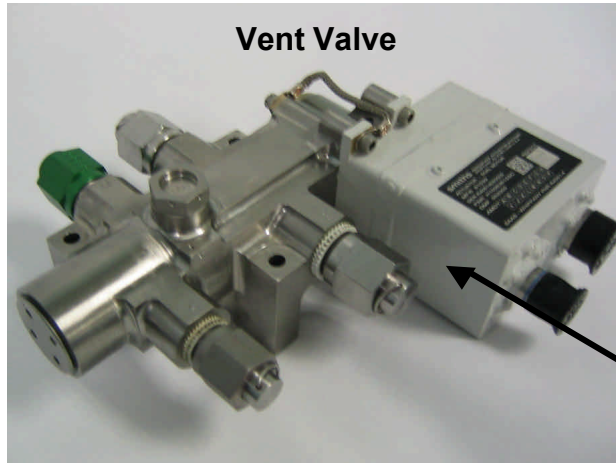

GE
Aviation

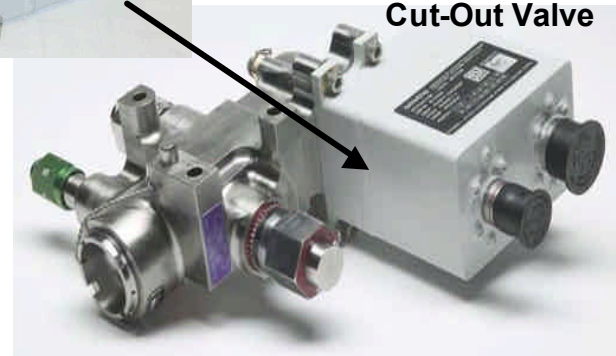
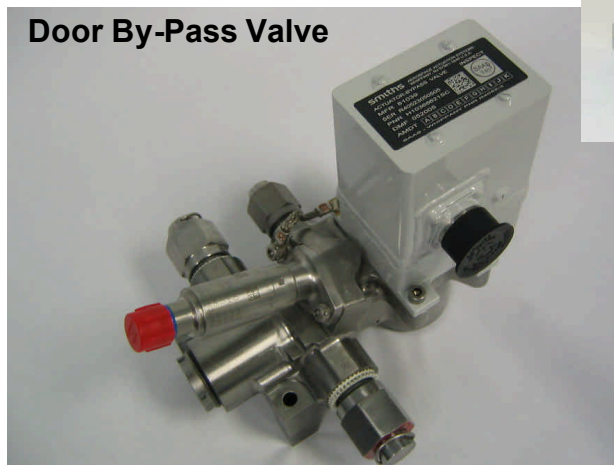

A380 Landing Gear & Systems – An Overview

Extension/Retraction System Equipment

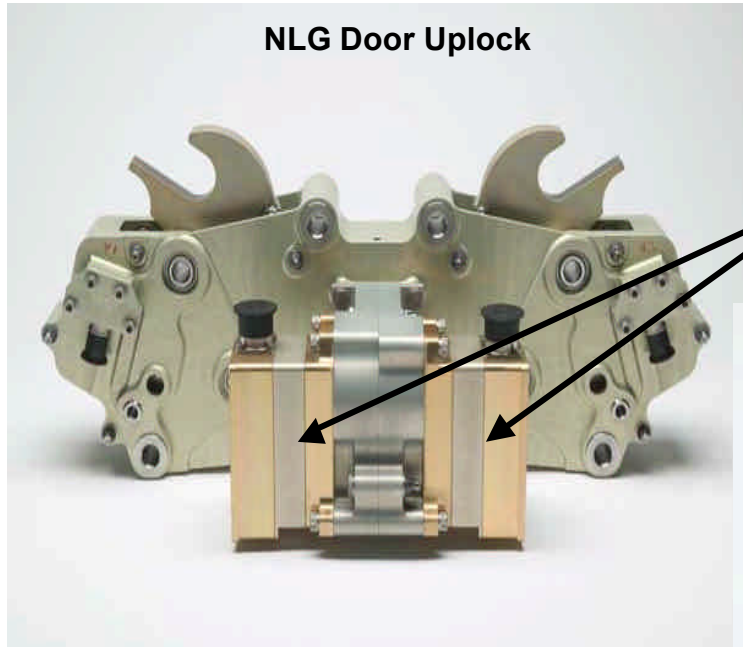

GE
Aviation

A380 Landing Gear & Systems – An Overview

Ext/Ret - Ground Door Opening

- System operation is from a Control Panel, which is accessible from outside the aircraft and located near the operated door(s). There is a Control Panel for;
 - ▶ NLG (both doors)
 - ▶ L WLГ (one door)
 - ▶ R WLГ (one door)
 - ▶ L BLG (outer door only)
 - ▶ R BLG (outer door only)

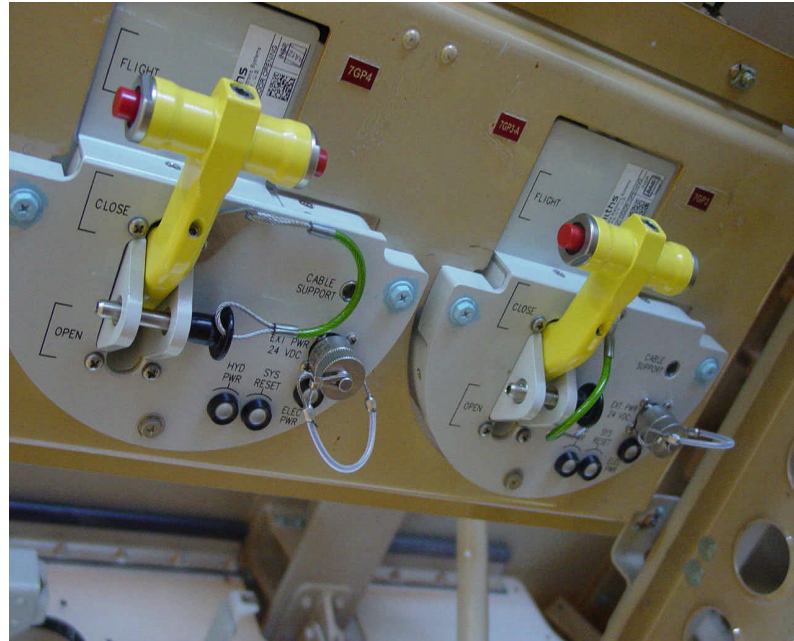

- Operation of system commands isolation of the Gear Door Actuator via a By-Pass Valve and release of the Door Uplock via the Side B EUA, allowing it open by gravity.

A380 Landing Gear & Systems – An Overview

Cockpit Controls and Indications

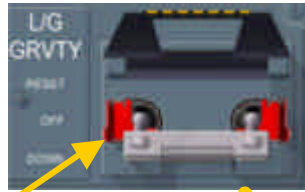

Landing Gear Emergency Extension Switches

Independent Landing Gear Position Lights



Brake Pressure Triple Gauge

Anti-Skid selector switch

Landing Mode Rotary Selector Switch

Landing Gear Selector

Steering Tiller

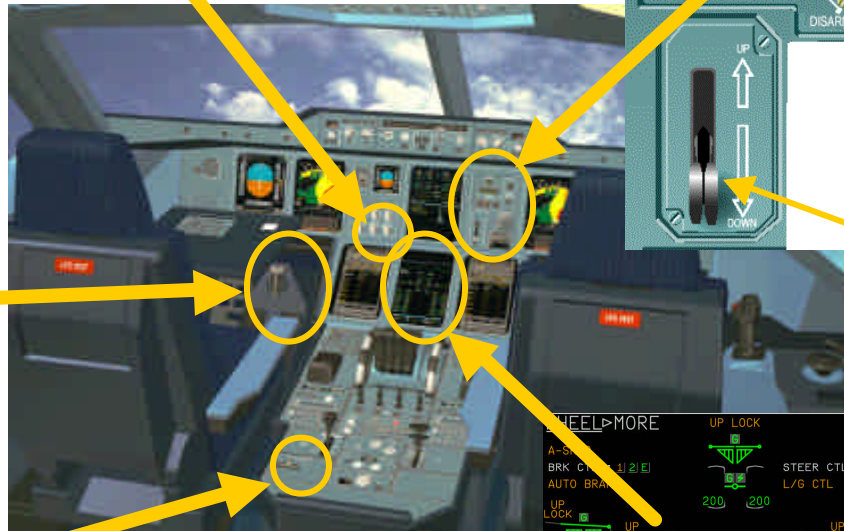

Brake Pedal Transmitters

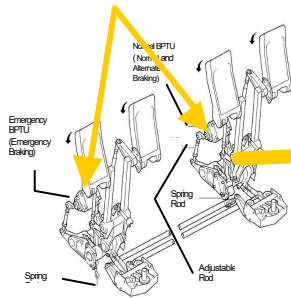

Parking Brake Selector

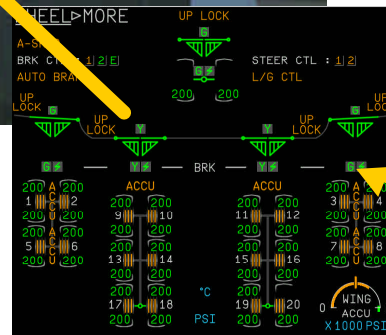

Systems Display (Wheel Page)

A380 Landing Gear & Systems – An Overview

Flight Test Highlights



A380 Landing Gear & Systems – An Overview Questions?

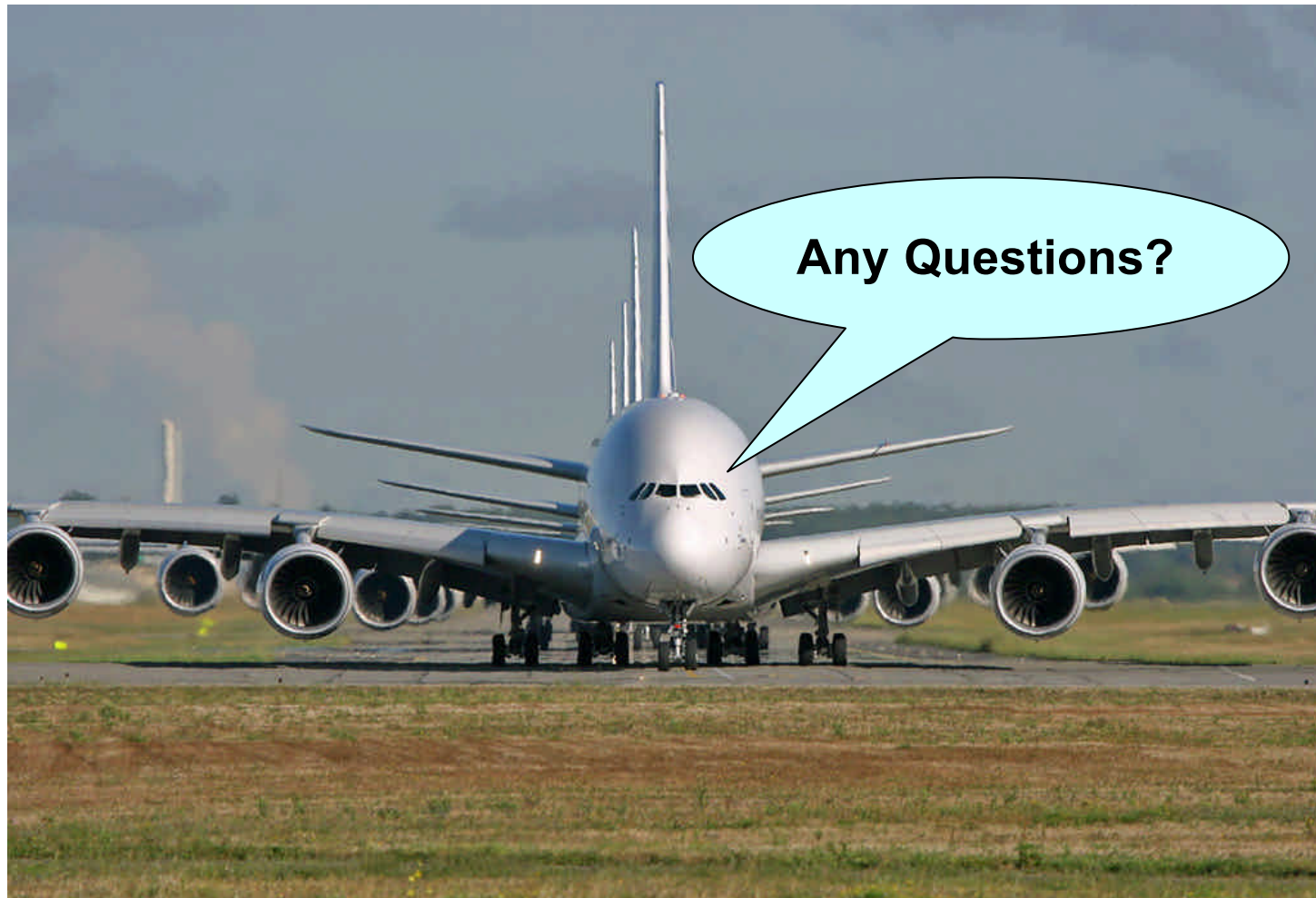

© AIRBUS UK LTD. All rights reserved. Confidential and proprietary document.

This document and all information contained herein is the sole property of AIRBUS UK LTD. No intellectual property rights are granted by the delivery of this document or the disclosure of its content. This document shall not be reproduced or disclosed to a third party without the express written consent of AIRBUS UK LTD. This document and its content shall not be used for any purpose other than that for which it is supplied.

The statements made herein do not constitute an offer. They are based on the mentioned assumptions and are expressed in good faith. Where the supporting grounds for these statements are not shown, AIRBUS UK LTD will be pleased to explain the basis thereof.

AIRBUS, its logo, A300, A310, A318, A319, A320, A321, A330, A340, A350, A380, A400M are registered trademarks.

