

Understanding The James Webb Space Telescope

Launch Date: 25th December 2021

John Thatcher CEng, MRAeS

DGLR/HAW/RAeS Hamburg Branch

31st March 2022

<https://doi.org/10.5281/zenodo.6415151>

JWST Historical Context

- The orbital space age began on 4th October 1957 when the USSR launched Sputnik 1, the first artificial Earth satellite and a momentous event in world history
- Last year marked 60 years since the first human went into space and orbited the Earth on 12th April 1961
- The Hubble Space Telescope was launched on 24th April 1990 and revolutionised our view of the Universe
- If all keeps going to plan, the James Webb Space Telescope (JWST) should be commissioned very soon - an event for astronomy that is likely to be even more momentous and revolutionary
- This talk provides an overview of how JWST came to be, why it looks the way it does and a preview of what is to come now that it has been successfully launched.

JWST Background

- The origins of JWST were in the mid-1990's when the next generation space telescope after Hubble was being formulated
- Looking far into space is also looking far back in time and the goal was to look back to the very first stars and galaxies that lit up some time after the 'Big Bang' - something which Hubble is simply not able to do - so different capabilities are required
- This new space telescope was the top priority of the US National Academy of Sciences in their 2001 report '*Astronomy and Astrophysics in the New Millennium*'
- The UK has a key role in leading a multi-national group that provides one of the 4 instruments on JWST with the lead scientist (Principal Investigator) based at the Royal Observatory, Edinburgh
- I was the Project Manager for this UK-led instrument for the 10 years leading up to its delivery to NASA in 2012 - based at Airbus Stevenage but effectively operating independently to manage the European Consortium to design, build and test the instrument.

Why Name the Observatory 'James Webb'?

- In 1961 NASA had only modest stature in federal circles - there was a view that the 'Buck Rogers nonsense' would quieten down once an American was put into space
- After John F Kennedy became President in January 1961 at least 17 people of great merit turned down his requests to become the new chief of NASA, not least due to the prospect of dealing with the Vice-President, Lyndon B Johnson, who led the Space Council
- James Webb, a 55 year old lawyer and ex-Under Secretary of State, was persuaded by Kennedy to become the second NASA Administrator (and went on to become arguably the greatest in NASA's 63-year history)
- Webb became the NASA chief ('The Administrator' in US Government-speak) in February 1961.

John F Kennedy & James (Jim) Webb



Two Months After James Webb Heads NASA

Page	Page
Amby 11	Editorials 4
Amusements 6	Sports 22
Comics 25	Society 3
Crossword 28	Ward Ads 26
Jumble 14	Radio-TV 26

25 PAGES TODAY

The Huntsville Times



VOL. 51, NO. 21

CHICAGO DAILY NEWS SERVICE

HUNTSVILLE, ALABAMA, WEDNESDAY, APR. 12, 1961

ASSOCIATED PRESS — WIREPHOTO

45c PER WEEK

Man Enters Space

'So Close, Yet So Far,' Sighs Cape U. S. Had Hoped For Own Launch

CAPE CANAVERAL, Fla. (AP) — The Redstone rocket which the United States had hoped would boost the first man into space stands on a launching pad here. The Soviet Union beat its firing date by at least two weeks.

"So close, yet so far," commented a technician who is helping groom the Redstone to send one of America's astronauts on a short sub-orbital flight, hopefully late this month or early in May.

Hobbs Admits 1944

"If we hadn't had those troubles last fall and on the chimp and Little Joe shots this year, we might have made it," the technician said.

"But you have to give the Russian scientists credit. They've ac-



Soviet Officer Orbits Globe In 5-Ton Ship Maximum Height Reached Reported As 188 Miles

MOSCOW (AP)—A Soviet astronaut has orbited the globe for more than an hour and returned safely to receive the plaudits of scientists and political leaders alike. Soviet announcement of the feat brought praise from President Kennedy and U. S. space experts left behind in the contest to put the first man into successful space flight.

By the Soviet account, Maj. Yuri Alekseyevich Gagarin, rode a five-ton spaceship once around the earth in an orbit taking an hour and 20 minutes. He was in the air a total of an hour and 48 minutes.

The whole sequence of events and the announcements relating to it raised a number of questions. The Soviet announcement said the flight took place today between 9:07 and 10:53 a.m., but some persons in

VON BRAUN'S REACTION:

To Keep Up, U. S. A. Must Run Like Hell'

Gagarin Led to Apollo

- There was an widely-held view that it was the German rocket scientist Wernher von Braun who drove the Apollo program to the Moon
- In fact, more than anyone else, James Webb was the man who ensured that America eventually won the space race by landing two men on the Moon in 1969 (although Webb left NASA in 1968 after a show trial - his reputation has since been mainly restored)
- James Webb found himself in charge of the largest, costliest and most ambitious engineering project in human history just 3 months after stepping into NASA HQ
- Webb steered the expansion of NASA from a minor collection of research laboratories into one of the grandest enterprises the world has ever seen - a legend and a legacy that he was pivotal in creating.

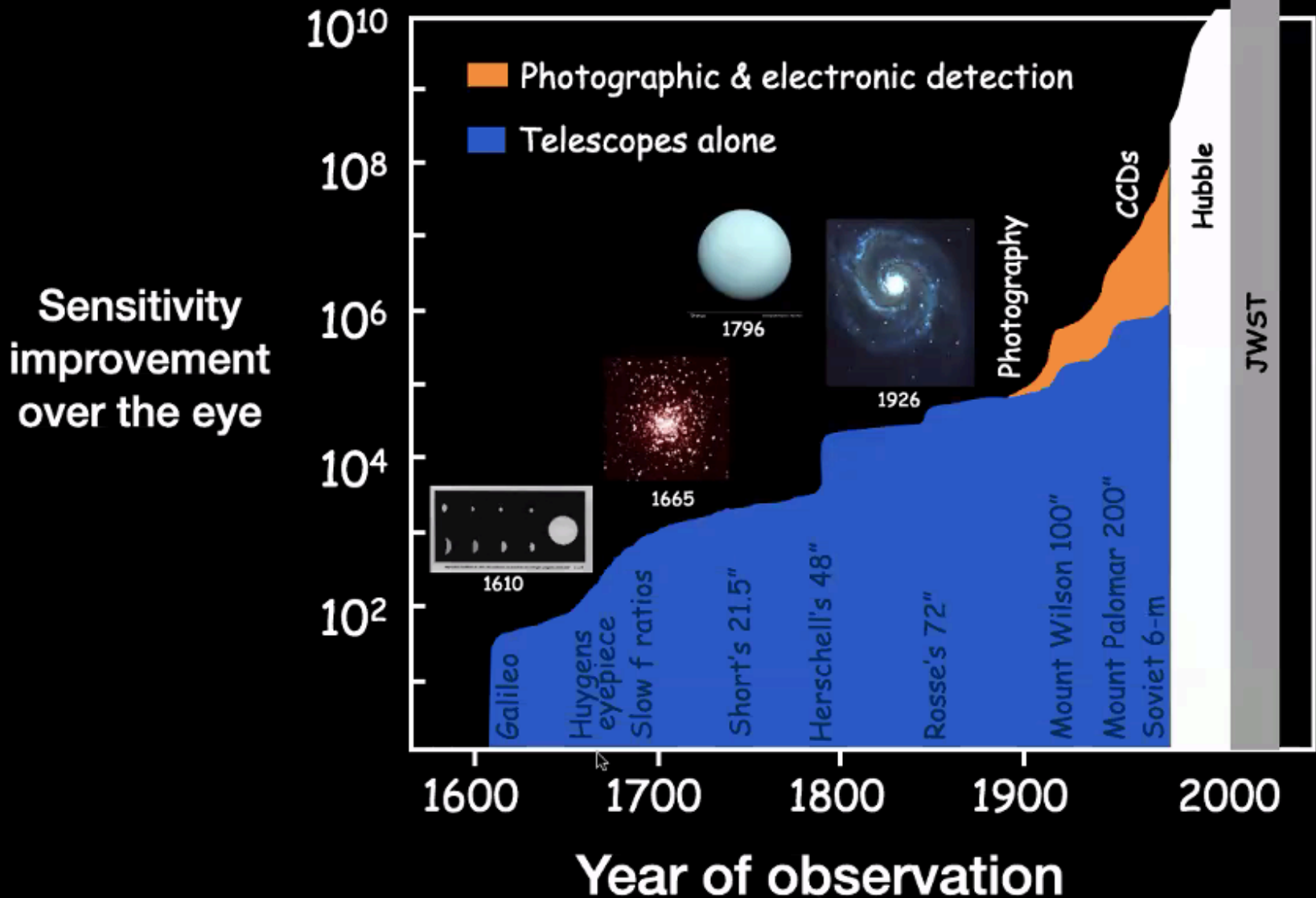
James Webb and Space Science

- Jim Webb was the driving force behind Project Apollo (and he did much to knock NASA into a more cohesive organisation by ensuring all the politics went through him) but he was not focussed on just the Moon, he believed it important to do space science as a parallel activity
- Of particular note, in his early days Webb saved JPL from having its funds cut by Congress because of the significant number of failures of JPL projects (cf SpaceX)
- Webb also clashed with the GSFC Director over the role of NASA HQ in those early days but at the same time he supported their scientific satellite work and took an early interest in what became the Hubble Space Telescope
- It is not surprising then that the project to follow Hubble is named the James Webb Space Telescope (JWST).

Hubble Space Telescope



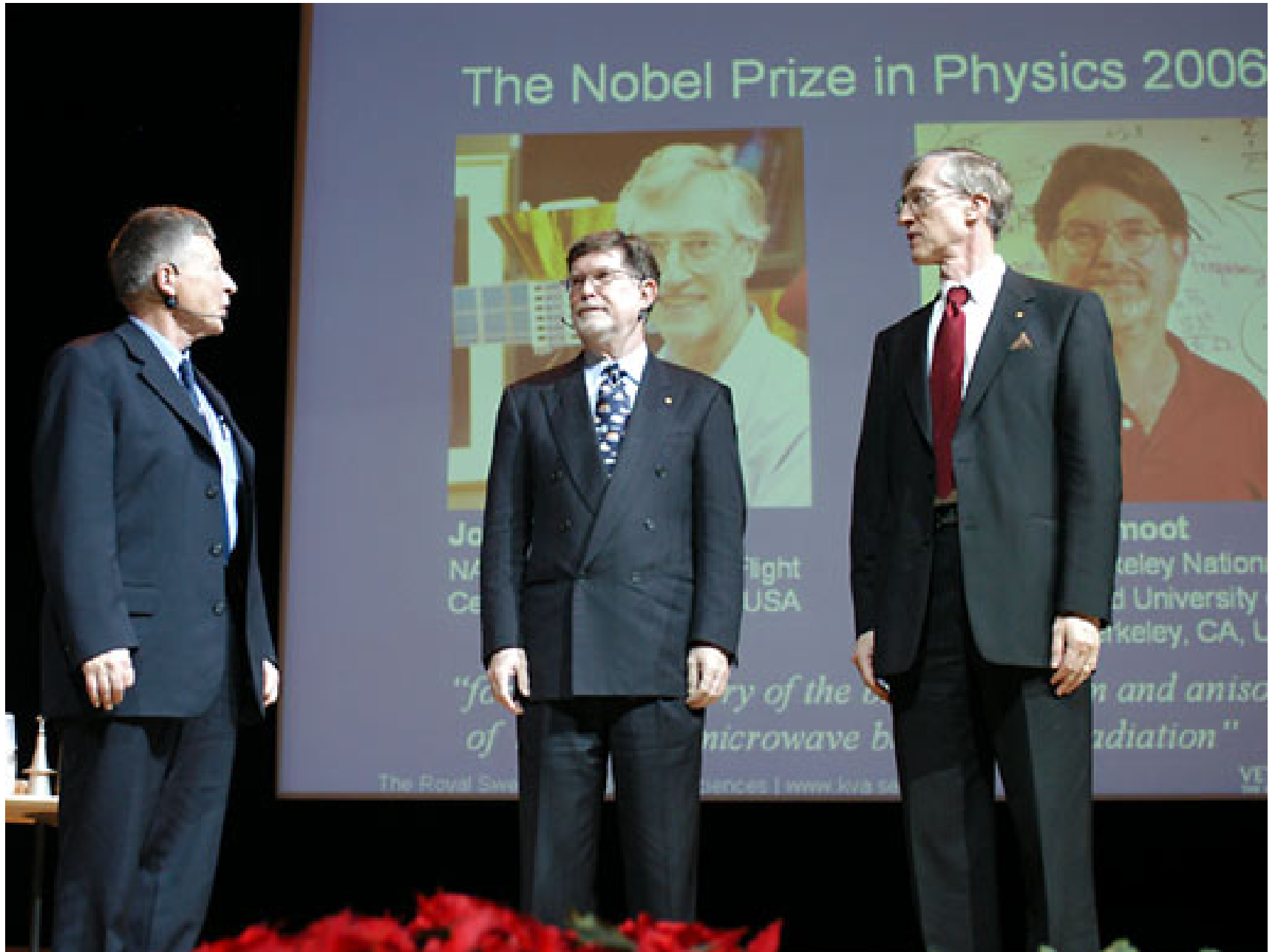
Our Ability to See into the Universe



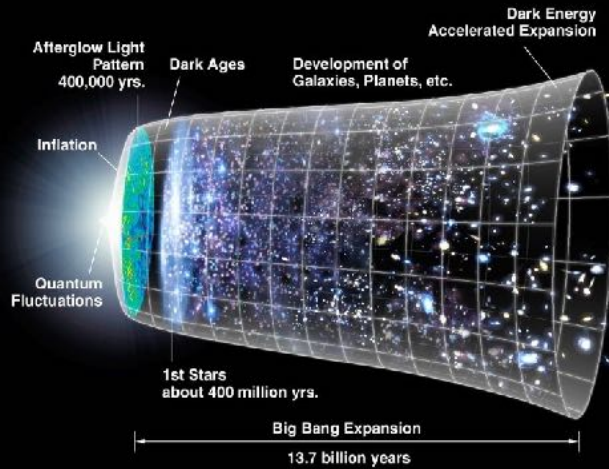
JWST Key Points

- JWST (or just 'Webb' as NASA now prefer) is the scientific successor to the Hubble Space Telescope, not its replacement
- It is a joint mission by NASA, ESA (European Space Agency) & CSA (Canadian Space Agency)
- The Observatory is optimised for making infra-red observations (wavelengths 0.6 – 28 microns) in order to study the origin and evolution of galaxies, stars and planetary systems
- The primary mirror is 6.5 metres across and was folded to fit inside the European Ariane 5 rocket that launched it
- Webb operates way outside Earth orbit and is in fact in orbit around the Sun tracking around the Sun at the same rate as the Earth
- The telescope and most of its instruments operate at cryogenic temperatures (40K = -233C) to get the necessary infrared performance to deliver the desired science.

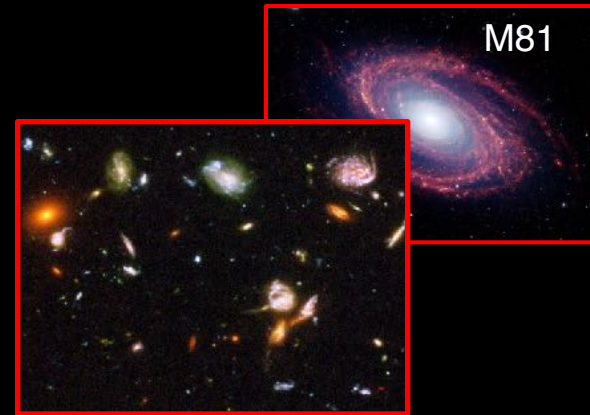
Webb's Lead Scientist is a Nobel Prize Winner



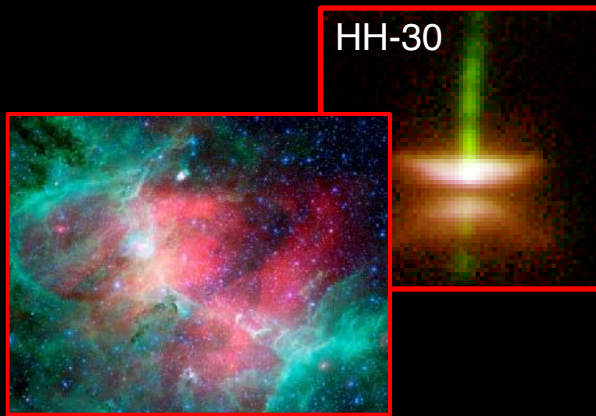
The Key Science Goals for JWST



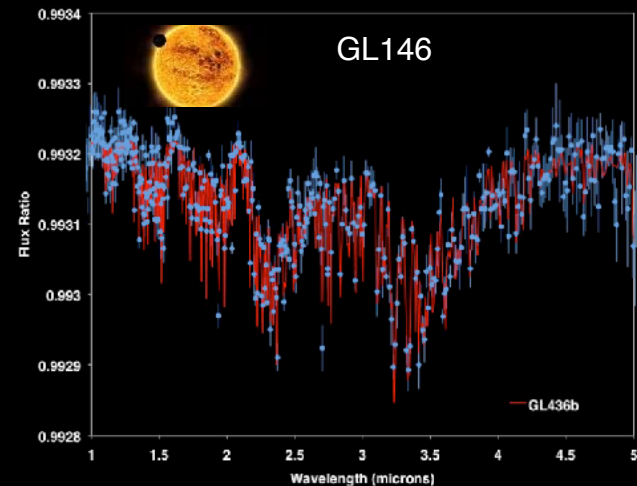
First Light and Re-Ionization



Assembly of Galaxies



Birth of Stars and Proto-planetary Systems

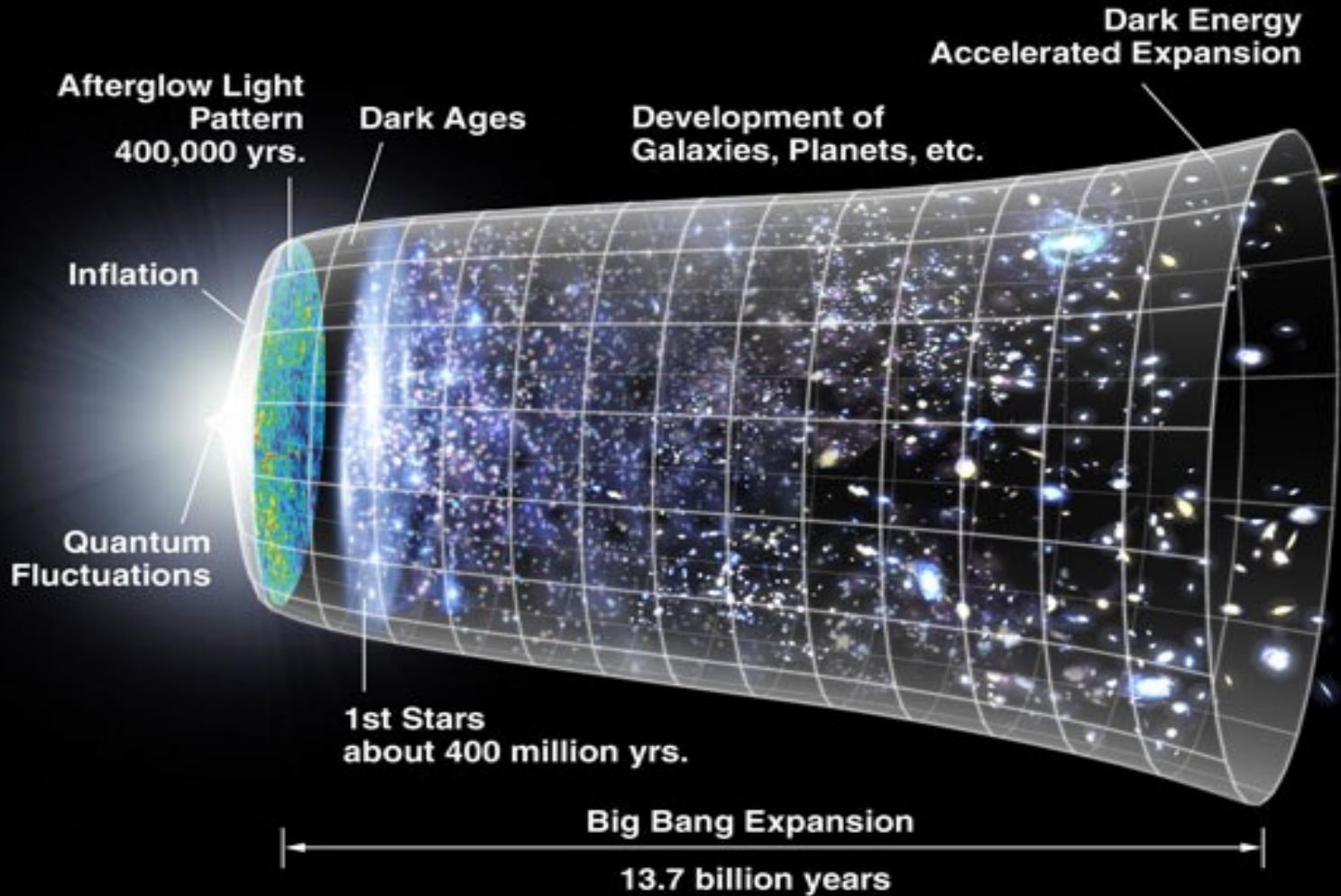


Planetary Systems and the Origin of Life

First Light & Re-ionisation

- Goal is to identify the first luminous sources to form and to determine the ionisation history of the early universe
- After the 'Big Bang' all particles were ionised but, when the universe had cooled sufficiently, protons and electrons combined to form hydrogen atoms and the opaque universe became transparent - the origin of the Cosmic Microwave Background - about 380,000 years after the 'Big Bang'
- There were no stars at this time so the Universe was essentially dark and the time until the first stars were born was not certain to within several hundred million years until recently
- 'First light' describes the appearance of the first stars or super-star clusters which burned hot and fast and re-ionised the surrounding gases - the 'Epoch of Re-ionisation'
- In more poetic terms, 'first light' marked the end of the cosmic 'dark ages' with the arrival of the 'cosmic dawn'.

First Light & Re-Ionisation



Science Goals Drive Observatory Design

- Size matters for a telescope and the initial goal was for an 8m diameter primary mirror - ***this is a bigger diameter than any rocket fairing and so a 'foldable' primary mirror is needed***
- The goal is to look further back in space and time than Hubble but this cannot be achieved in visible light as the expansion of the universe had stretched the wavelength of this early light - ***an infra-red observatory is now required to see that early UV and visible light and it must be in space***
(because the Earth's atmosphere absorbs most infra-red radiation, a ground-based telescope simply will not work at these wavelengths - so a space telescope is essential)
- Infra-red radiation is essentially heat so JWST's infra-red instruments must not detect themselves! - ***these instruments need to operate at a temperature of 40K (-233C) or colder to achieve the needed science goals.***

Science Goals Drive Observatory Design

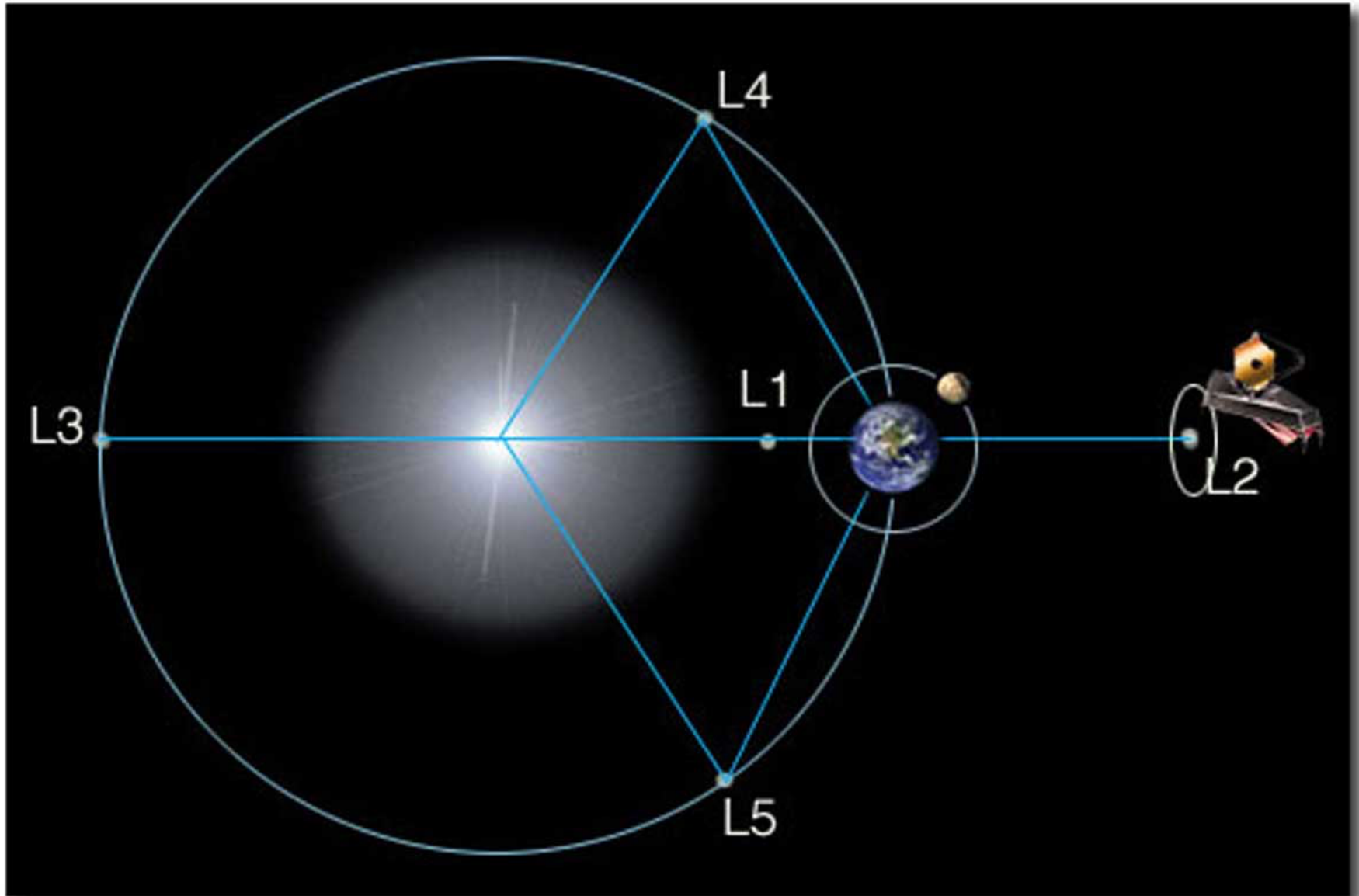
- The initial goal for observatory lifetime is a minimum of 5 years operations with a target of 10 years - ***JWST cannot be in low Earth orbit like Hubble***
- Low Earth orbit exposes a spacecraft to the heat from the planet which is at very high temperature compared with the temperature at which an infrared observatory needs to operate
- Small observatories have managed to be in low Earth orbit by carrying coolant but this constantly boils off and limits lifetime
- The amount of coolant needed for the size of JWST plus a ten year lifetime would make JWST impossibly large to launch
- ***The Observatory must therefore be designed to operate well away from the Earth and be shielded from the heat radiation from the Sun, Earth and Moon.***

How to Achieve Supercold Temperature

- A quasi-gravitationally stable, sun-orbital location exists where a spacecraft can be exposed to the natural deep freeze of space which is at a temperature of about 3K (-270C)
- This is known as the second Lagrange Point (or L2) - about 4 times further from the Earth than the Moon in the direction away from the Sun (and in reality a huge volume of space)
- Out there it is possible to passively cool the telescope & instruments to 40K (-233C) by staring at deep space **provided that** the telescope and instruments are shielded from the direct thermal radiation from the Sun, Earth & Moon **and also that** the telescope is thermally isolated from the spacecraft bus which needs to operate at about room temperature (~300K)
- To achieve the first requirement, a sunshield is needed that has to be a 5 layer 'parasol' the size of a tennis court and equivalent to a sun cream with an SPF of about 1.2 million - and it must also fold up to fit inside the rocket for launch.

The 5 Lagrange Points Around Earth's Orbit

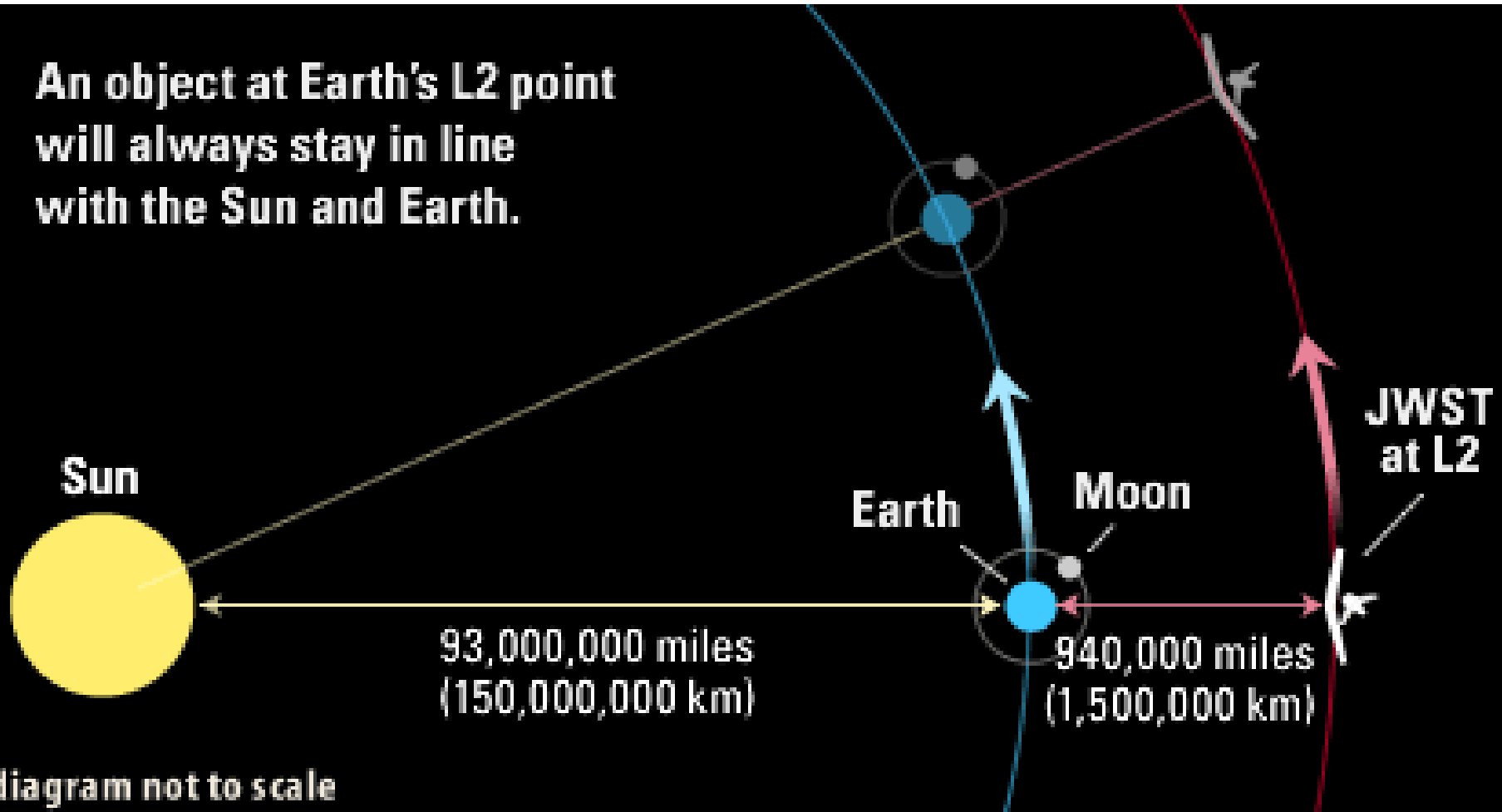
Definitely not to scale!



Another View of L2

Very definitely not to scale!!

An object at Earth's L2 point
will always stay in line
with the Sun and Earth.



Realising The Design

- It was soon apparent that an 8m diameter primary mirror was going to be too big and too expensive even for NASA
- Reducing the primary mirror diameter to 6.5m meant the science goals could be met with only little compromise - but this still meant a folding and segmented mirror design (note the segments form a single large mirror with one focus)
- The Observatory required 10 simultaneous major technology development programmes to succeed of which the mirrors, sunshield and instruments were the most significant
- The Observatory is not going to be serviceable in operation like Hubble and is not going to look like any other space telescope flown before - there cannot be a telescope 'tube' at this size and so stray light control becomes another challenge
- The project needs to be international to spread the cost and encompass the best expertise available.

JWST System Hierarchy

James Webb Space Telescope System

Launch Segment



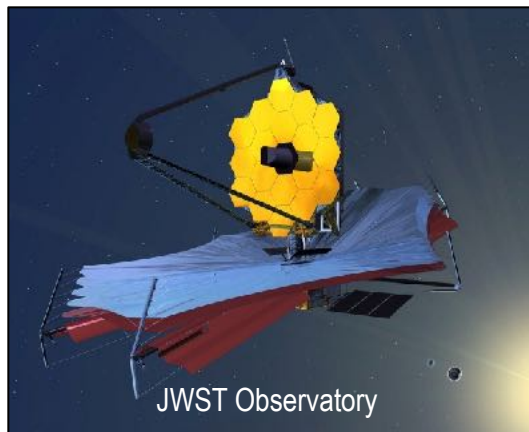
Ariane Launcher

Launch Vehicle

Payload Adapter

Launch Site Services

Observatory Segment



JWST Observatory

Optical Telescope Element (OTE)

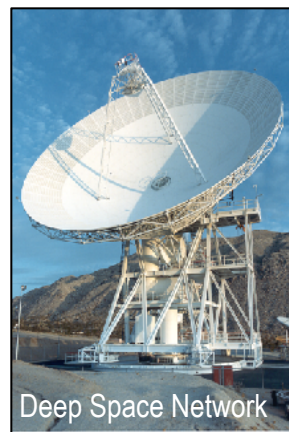
Integrated Science Instrument Module (ISIM)

Spacecraft Element (SE)

Spacecraft Bus

Sunshield

Ground Segment



Deep Space Network

Science and Operations Center (SOC)

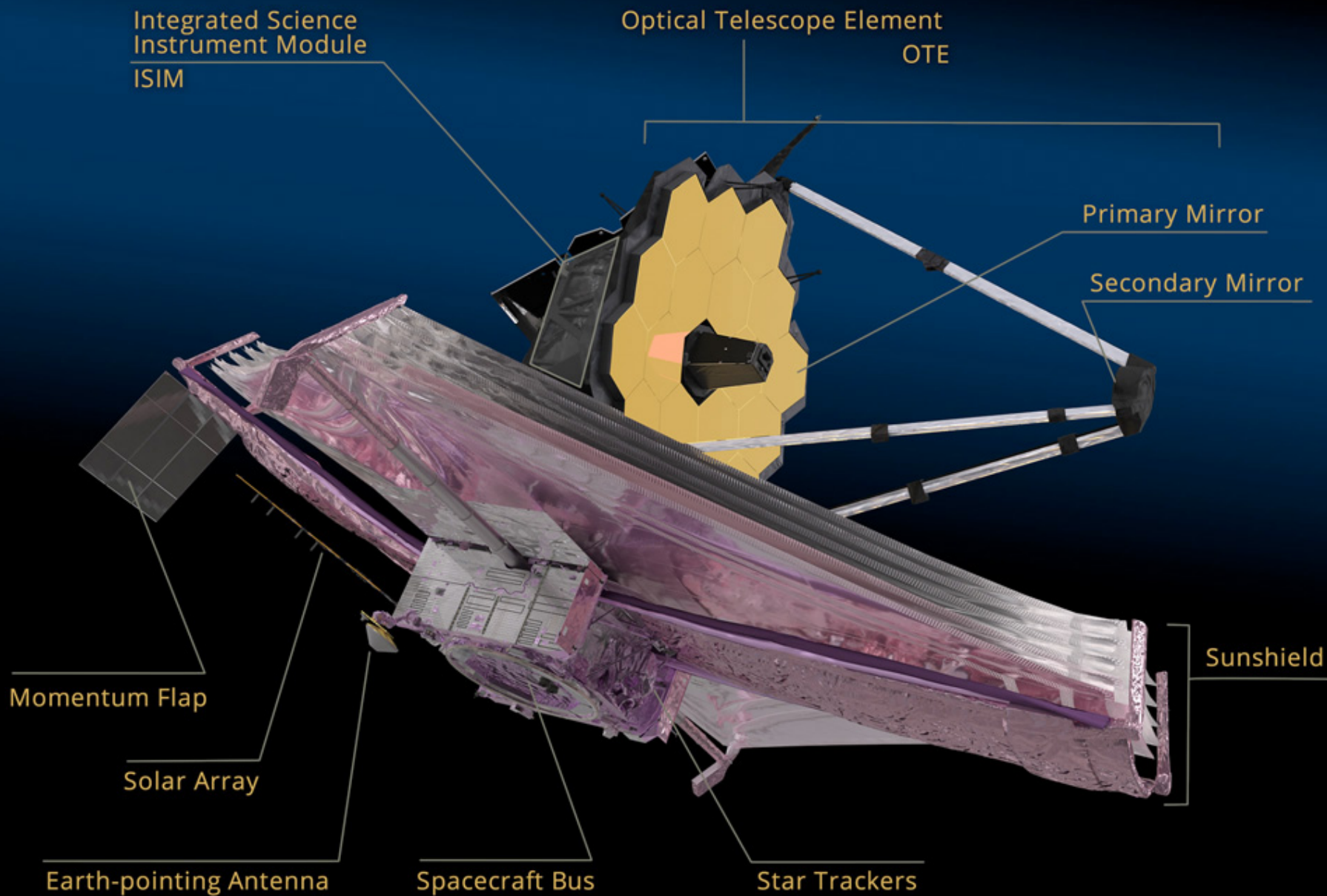
Institutional Services

Common Command And Telemetry System (CCTS)

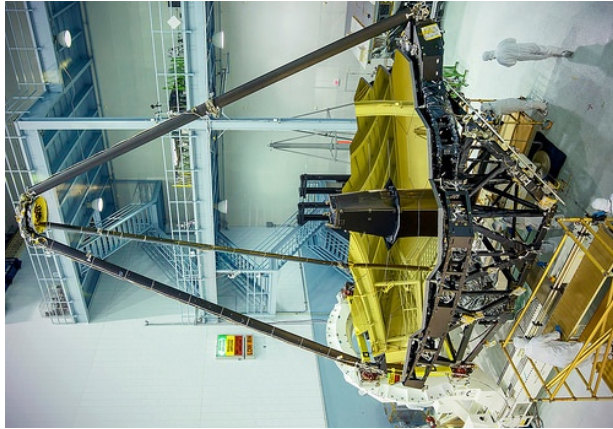


Space Telescope Science Institute

JWST – The Observatory

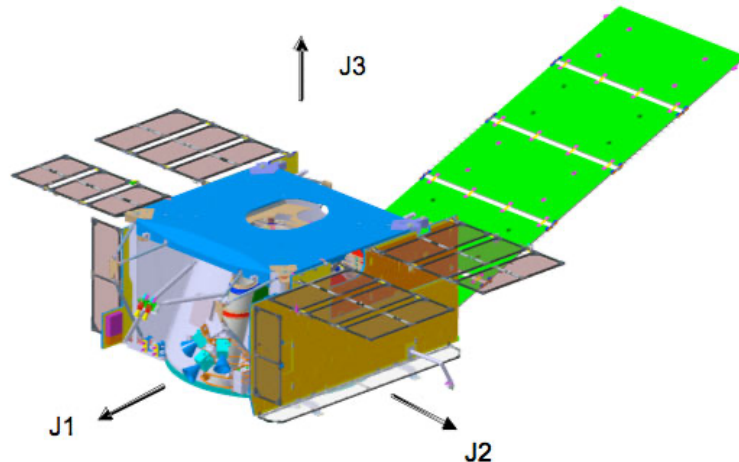
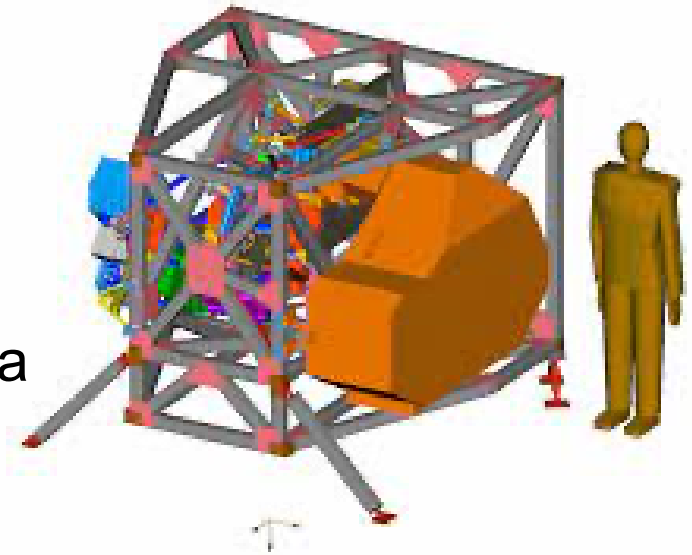


The 3 Interdependent Observatory Elements



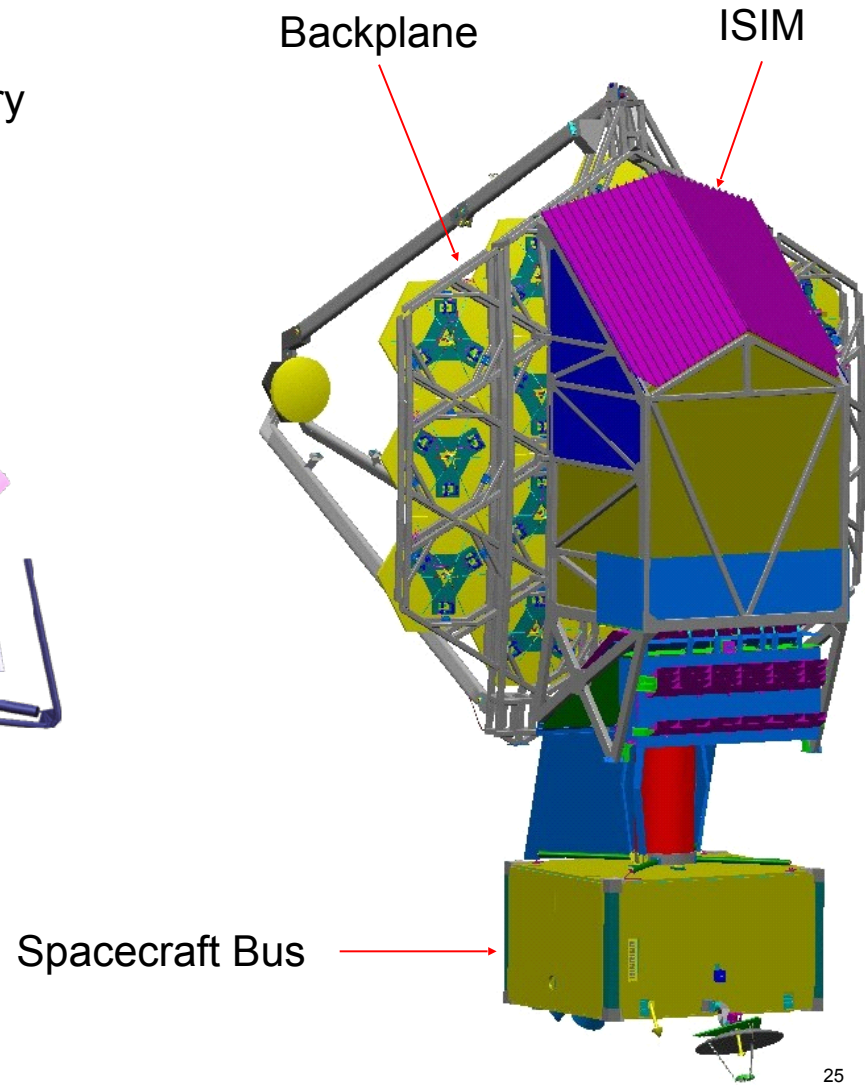
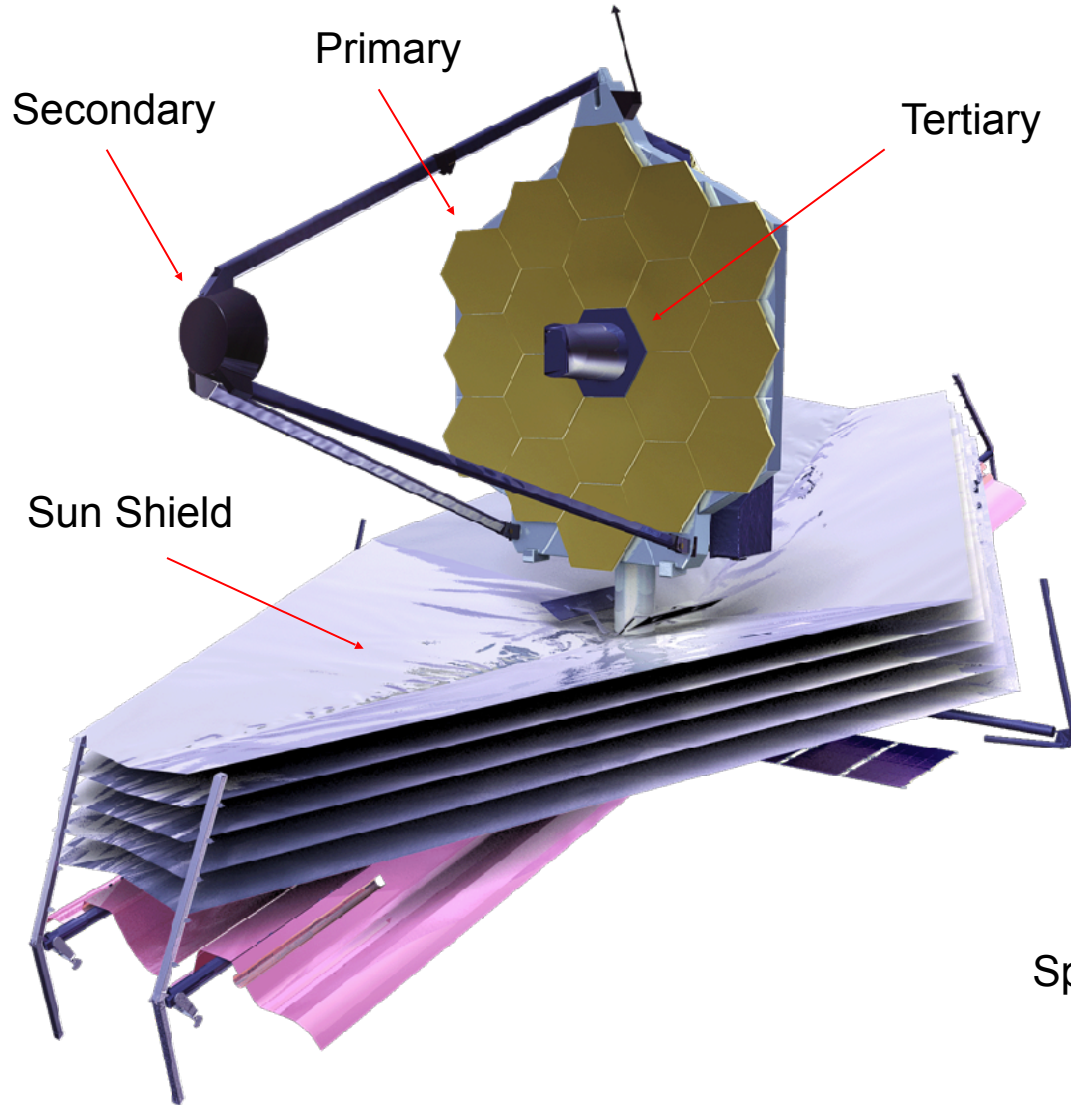
- TELESCOPE - gather & direct light into the instruments

- INSTRUMENTS - take images & analyse the light, turn them into data and send to the spacecraft bus



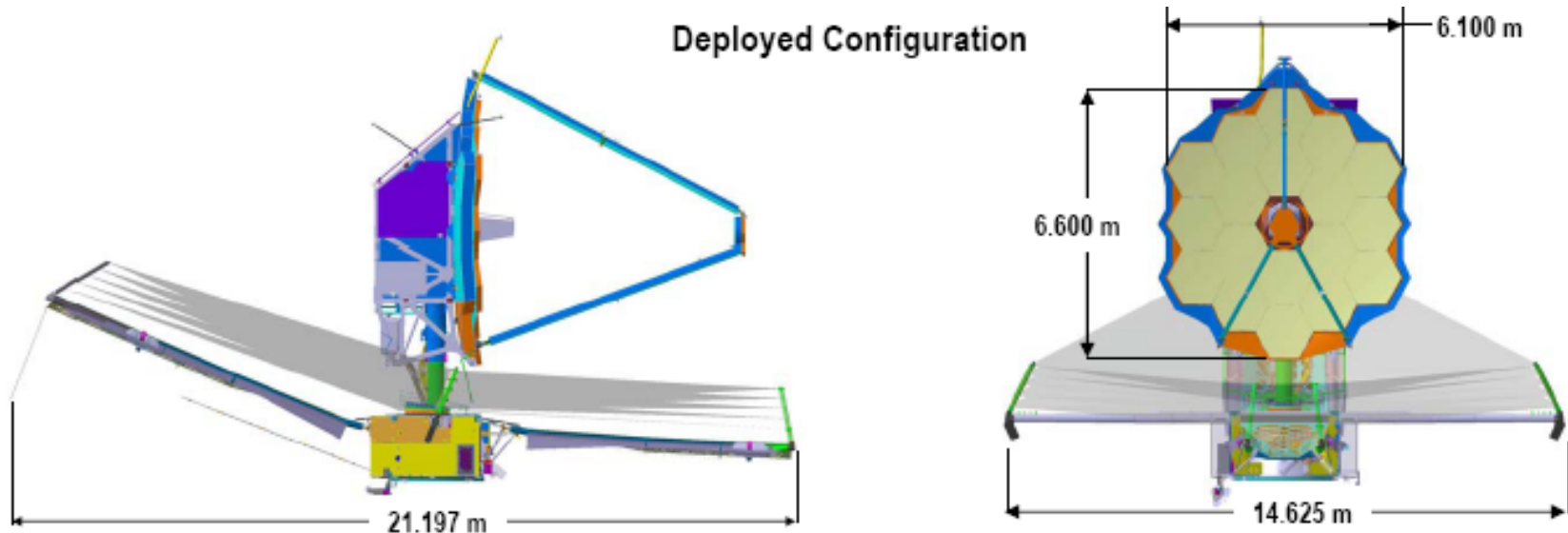
- SPACECRAFT BUS - provide the Observatory with power, pointing, propulsion, thermal control, data handling & communications with Earth

The JWST Observatory Elements Together

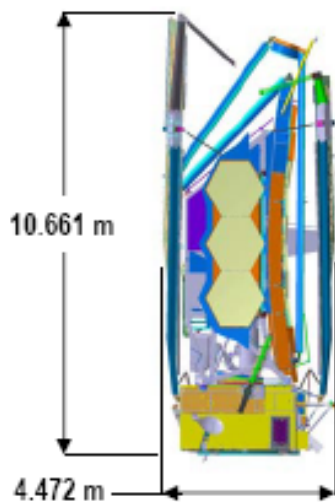


Some Dimensions - It's Big!

Deployed Configuration



Stowed Configuration



- Optical Telescope Element (OTE) diffraction limited at 2 micron wavelength.
 - 25 m², 6.3 m diameter aperture.
 - Instantaneous Field of View (FOV) ~ 9° X 18°.
 - Deployable Primary Mirror (PM) and Secondary Mirror (SM).
 - 18 Segment PM with 7 Degree of Freedom (DOF) adjustability on each.
- Integrated Science Instrument Module (ISIM) containing near and mid infrared cryogenic science instruments
 - The NIRCam SI functions as the on-board wavefront sensor for initial OTE alignment and phasing and periodic maintenance.
- Deployable sunshield for passive cooling of OTE and ISIM.
- Mass: < 6330 kg .
- Power Generation: 2000 Watts Solar Array.
- Data Capabilities: 471 Gbits on-board storage, 229 Gbits/day science data.
- Science Data Downlink: 28 Mbps.
- Life: Designed for 11 years (goal) of operation.

Definitely A Big Spacecraft!

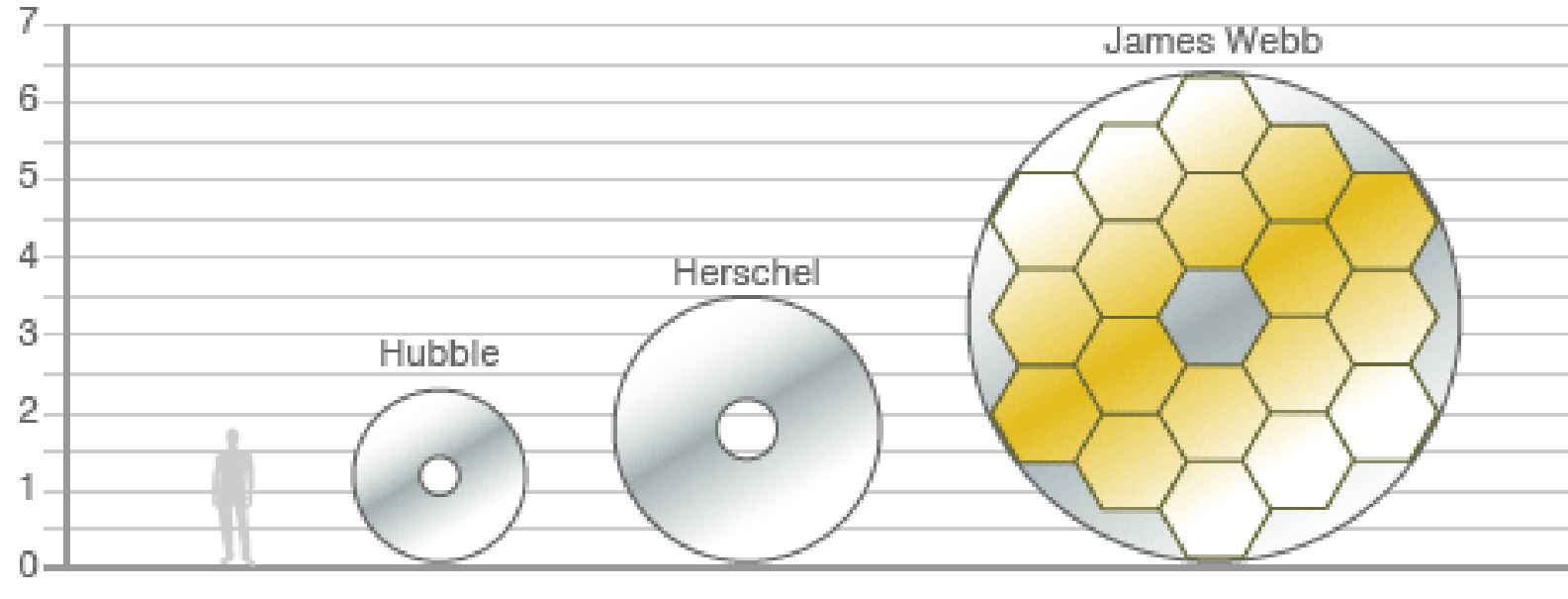
(JWST Full Size Model with NASA Goddard Team)



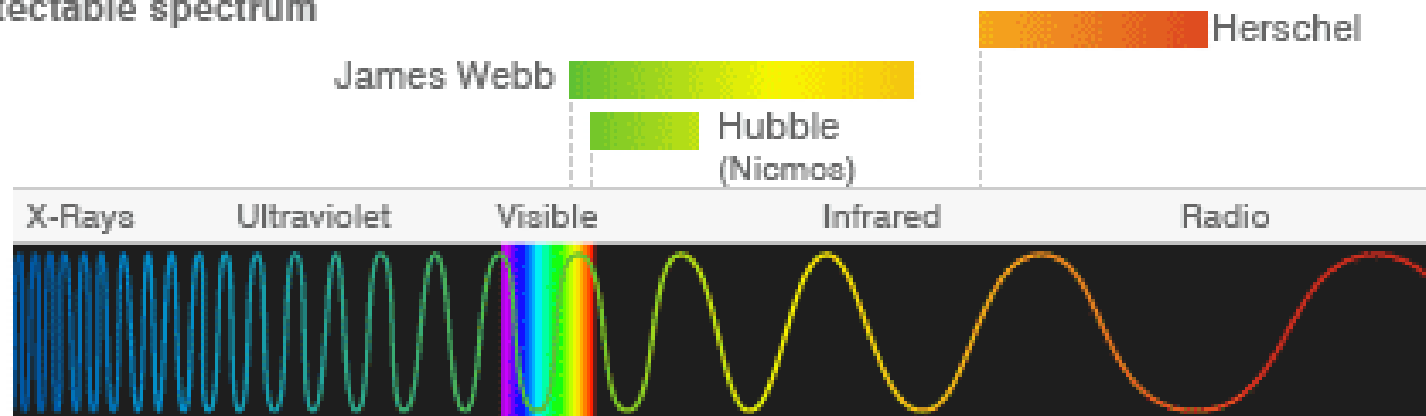
Primary Mirror Size Comparison

SPACE TELESCOPE COMPARISON

Mirror diameter (metres)



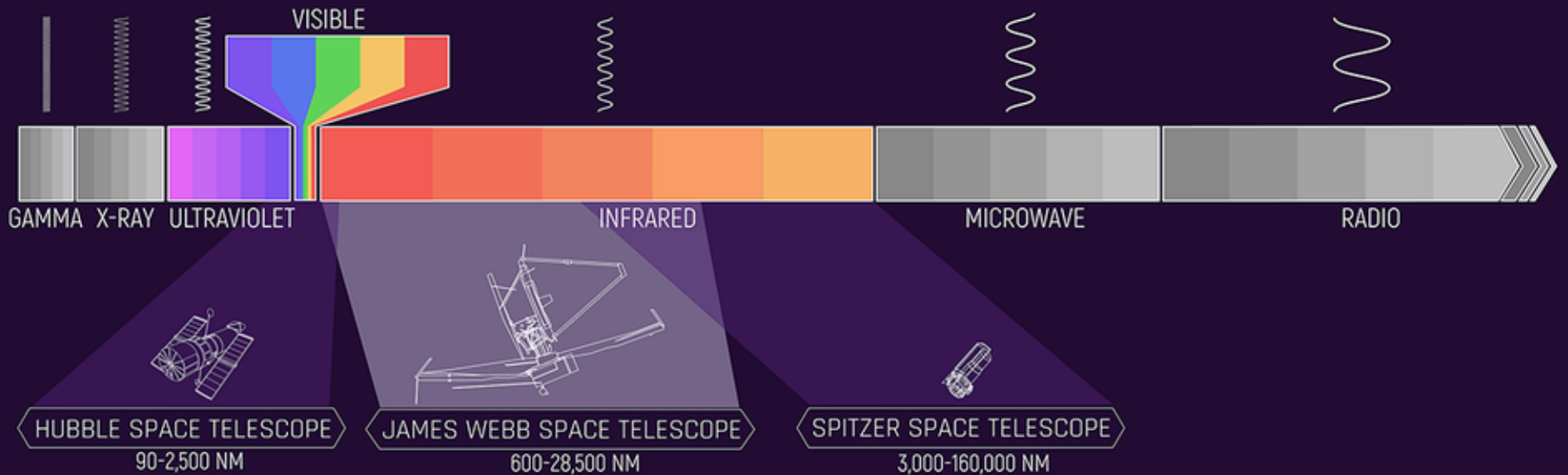
Detectable spectrum



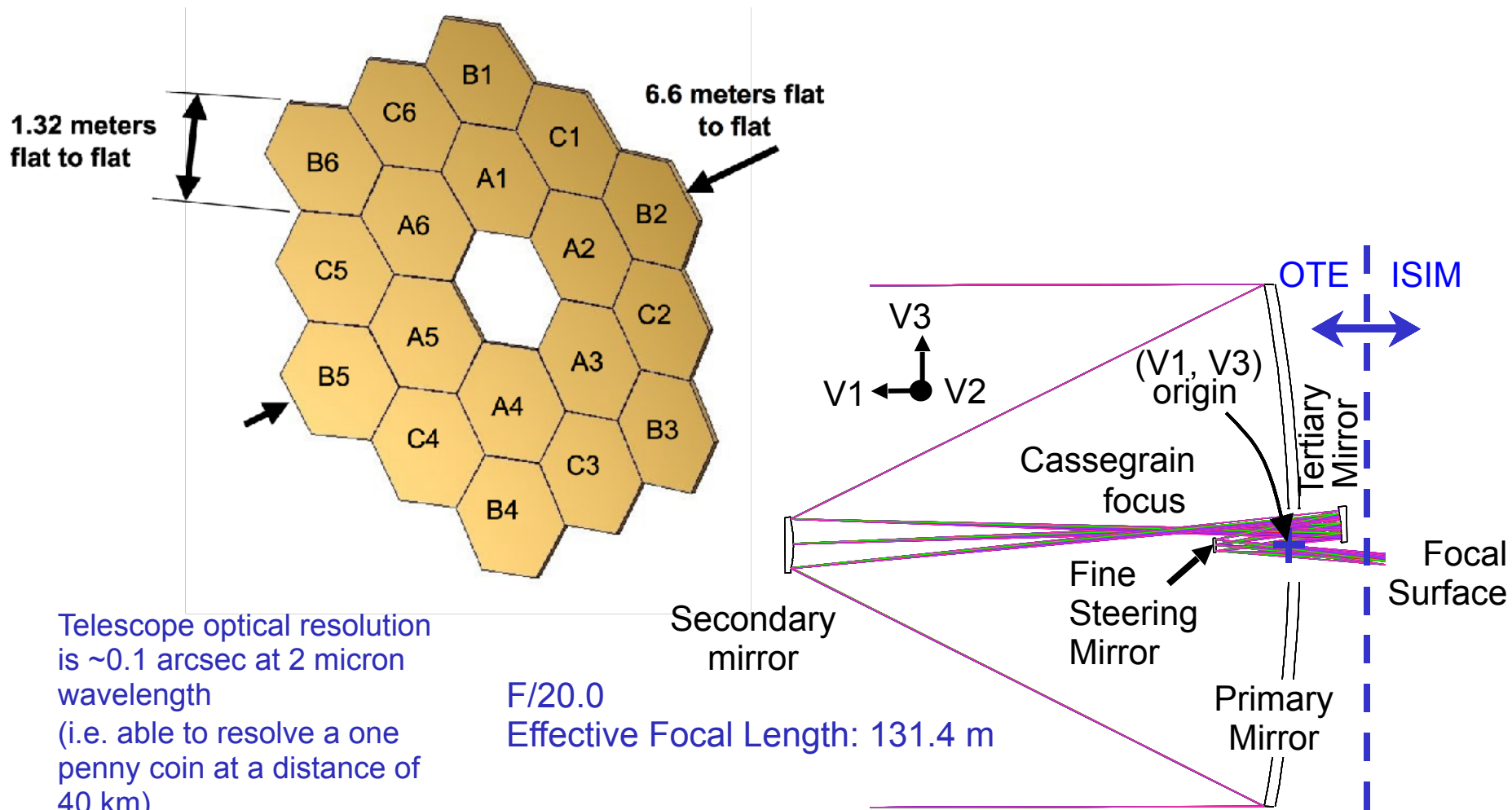
SOURCE: ESA

Where are They Observing?

ELECTROMAGNETIC SPECTRUM



Three Mirror Anastigmat Optical Design Provides a Wide Field-of-View



Telescope optical resolution is ~ 0.1 arcsec at 2 micron wavelength

(i.e. able to resolve a one penny coin at a distance of 40 km)

Thermally, can see a bee at the Moon's distance

F/20.0

Effective Focal Length: 131.4 m

JWST Takeaway Points

- **JWST is so scientifically powerful and able to address the key outstanding questions that it will transform astrophysics and cosmology**
- JWST will be the premier observatory of the next decade serving thousands of astronomers worldwide and will be complementary to the new generation of massive ground-based optical & radio telescopes
- JWST is also technically audacious - over 200 release & deployment devices with 155 motors and over 300 SPFs (Single Point Failures) - about 3x the number needed for a Mars landing!
- It does not come cheap - the ***lifetime*** cost is \$10 billion to NASA plus over €0.7 billion to ESA plus other European and Canadian national contributions...
- ...but that is still significantly less than one dollar per light year of looking back in space and time!
- Note also that NASA's total Artemis missions costs thru' fiscal 2025 are projected to reach \$93 billion (ie actuals will be more than this).

The Finished & Folded Observatory



Full 5-Layer Flight Sunshield

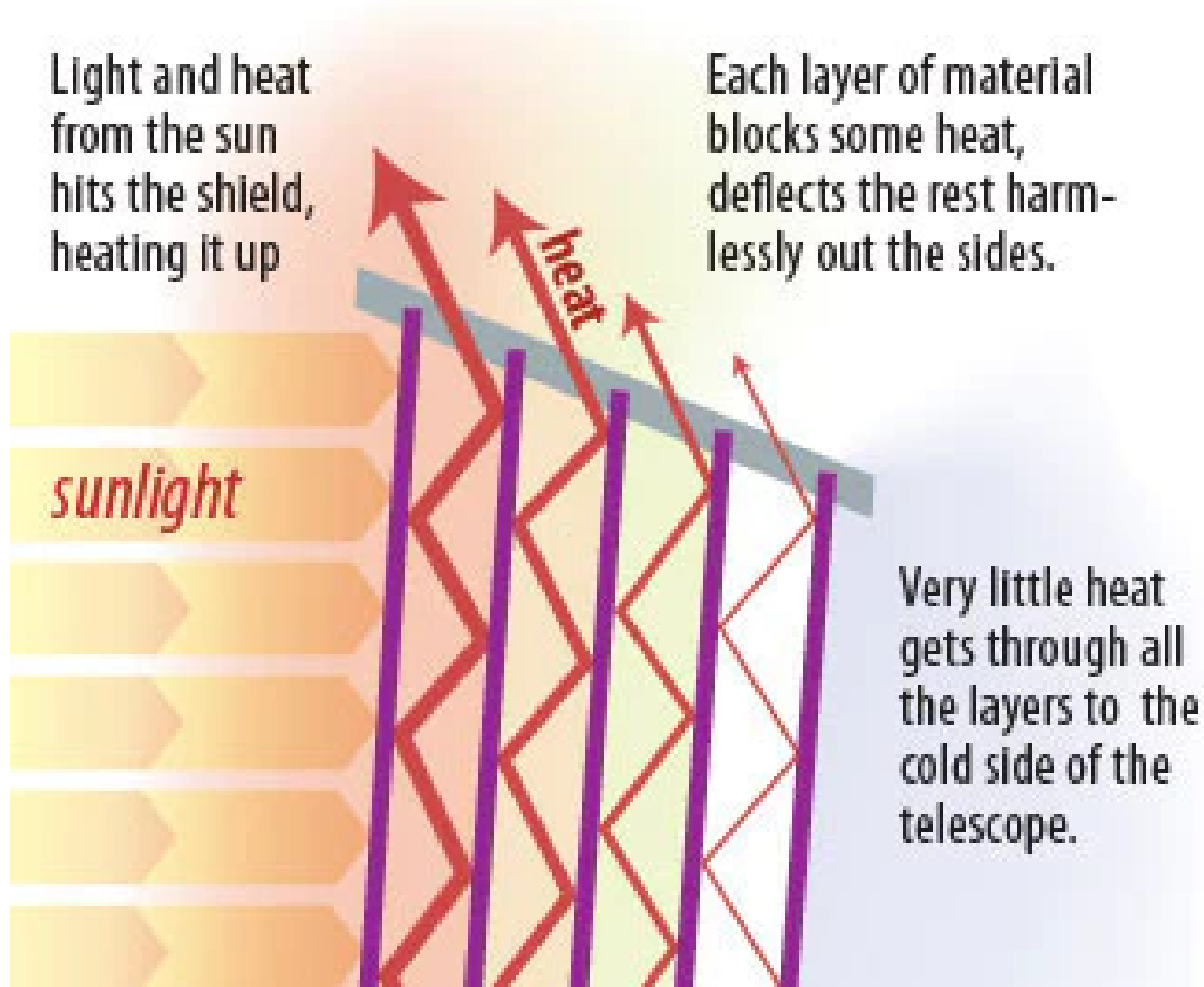


The Sunshield is Key to Cold Operation

- The sunshield is one of Webb's most critical and complex components enabling the telescope and instruments to be kept at extremely cold temperatures in order to detect the very faint heat signals from distant objects in the universe
- In space, one side of the sunshield will always reflect light and background heat from the Sun, Earth and Moon with the maximum temperature of the outermost layer reaching 383K (110C) whilst the other side of the sunshield will always face deep space with the coldest layer having a minimum temperature of 36K (-237C)
- The outermost layer of the sunshield is 50 microns thick (two thou' inch) while the other four layers are only 25 microns thick - imagine handling cling film sheets the size of a tennis court!
- The folding process is highly complex and has to account for components such as the sunshield's 90 different tensioning cables and over 600 pulley assemblies which must be stowed in a specific manner to ensure the sunshield deploys smoothly
- It is not surprising that the sunshield has been one of Webb's most challenging developments.

Sunshield Principle

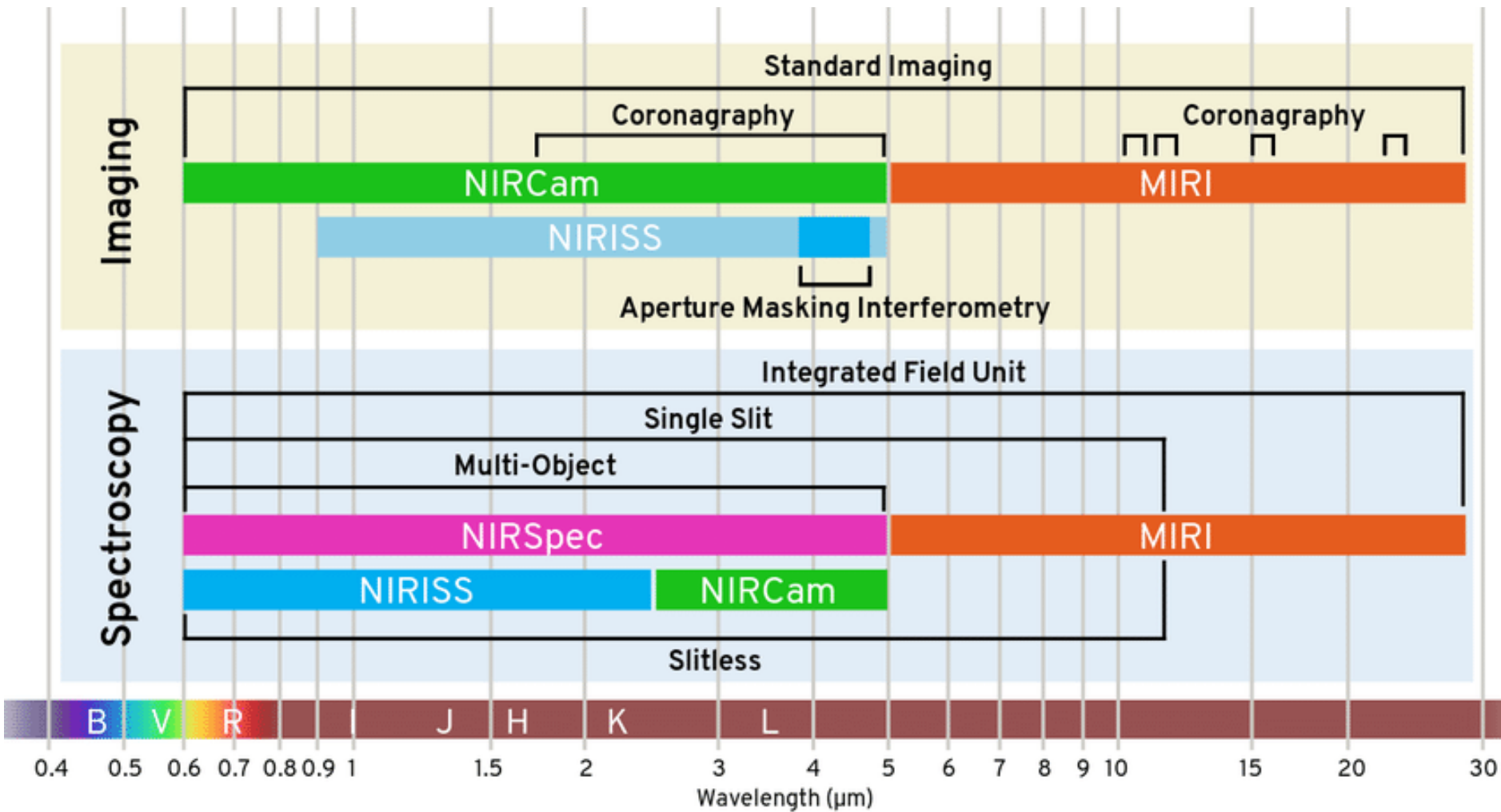
Cross-Section of Webb's Five-Layer Sunshield



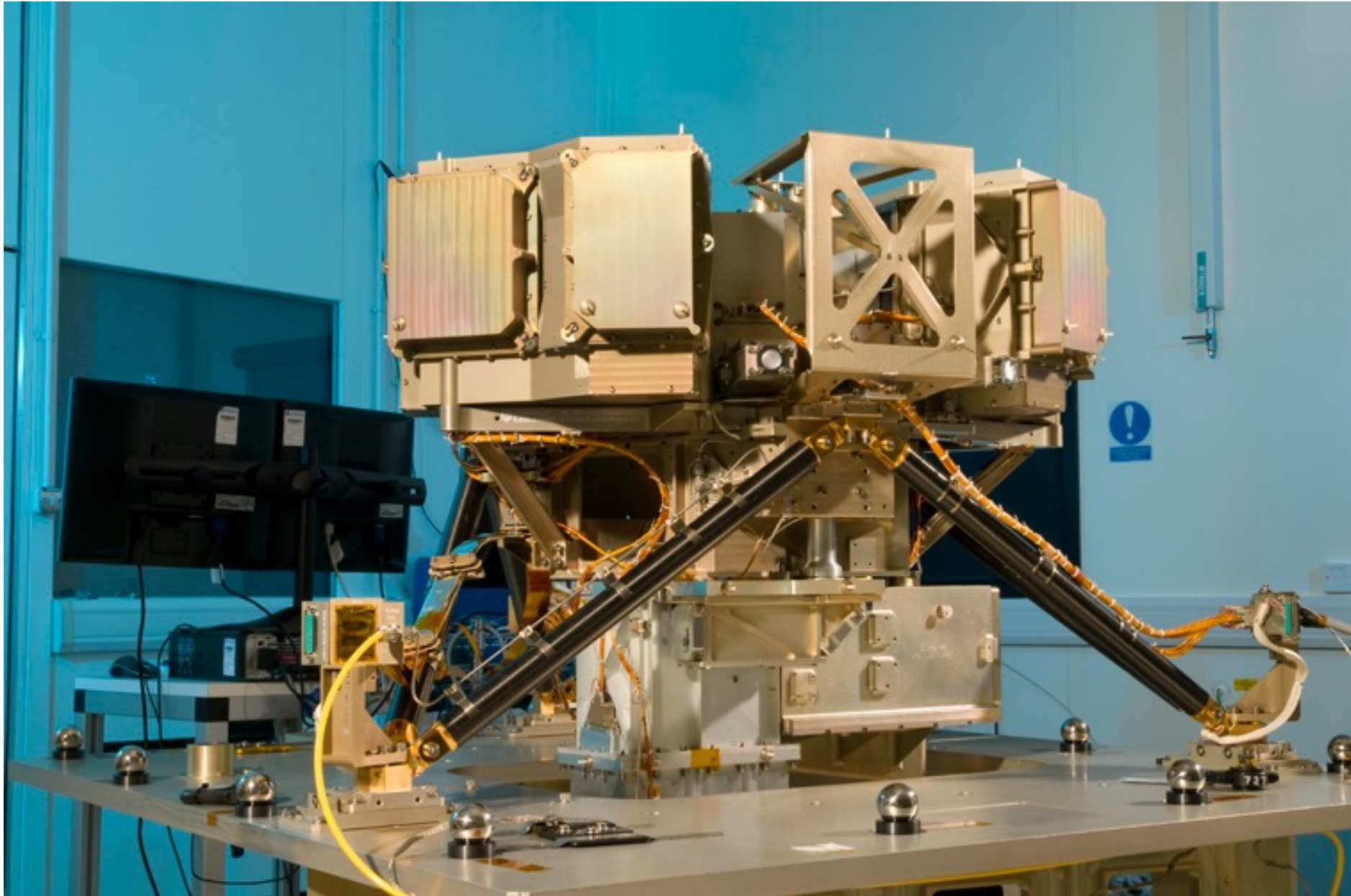
ISIM - Integrated Science Instrument Module



Science Instruments - Capabilities



What Does an Instrument Look Like?

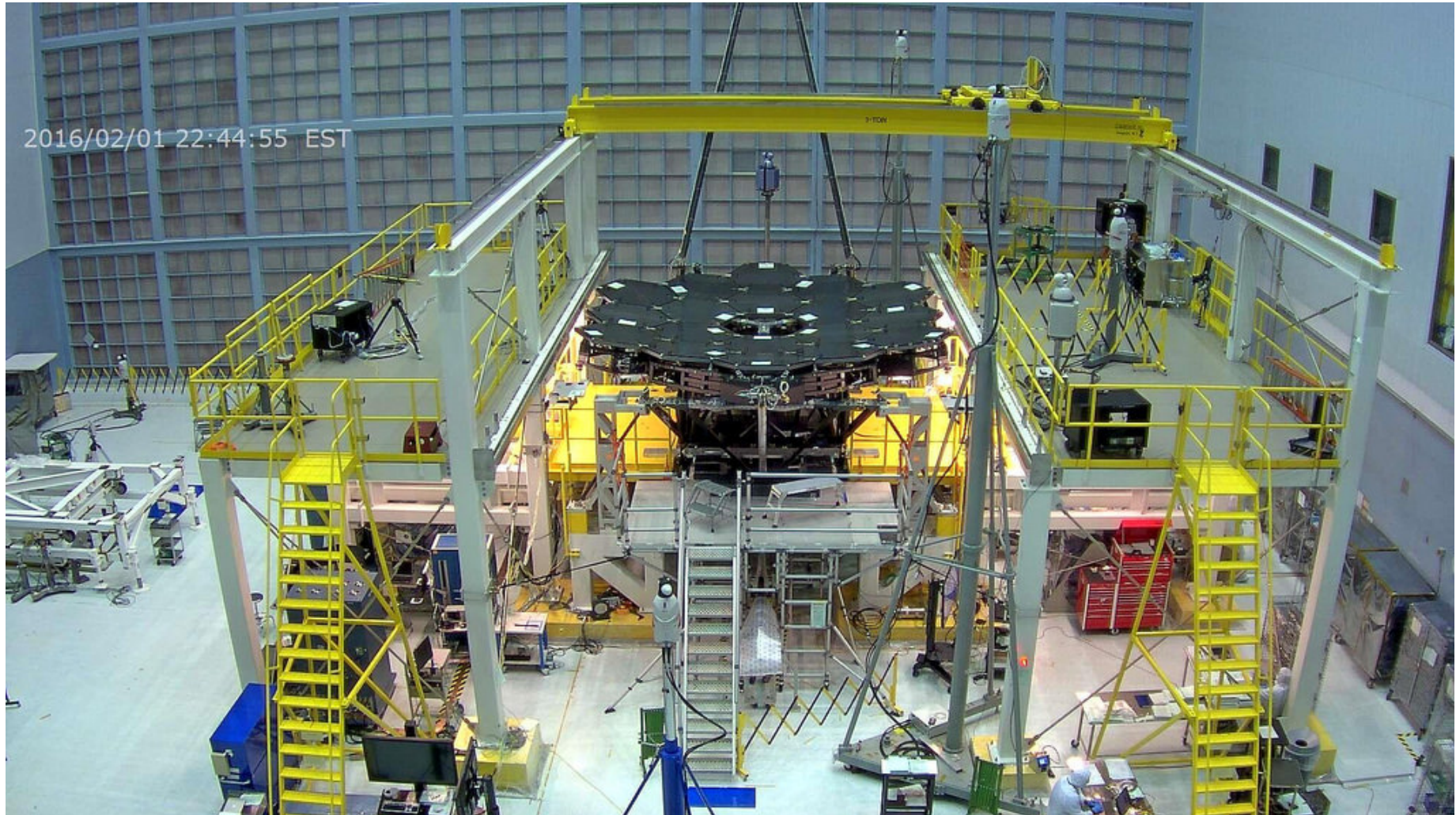


Mirror Acceptance Testing



There is a total of 48g (<2oz) of pure gold on all of the mirrors

Telescope Primary Mirror Integration



- Telescope structure and optics (OTE) assembled in GSFC clean room on test stand above
- ISIM then integrated to form **OTIS** (OTE + ISIM)

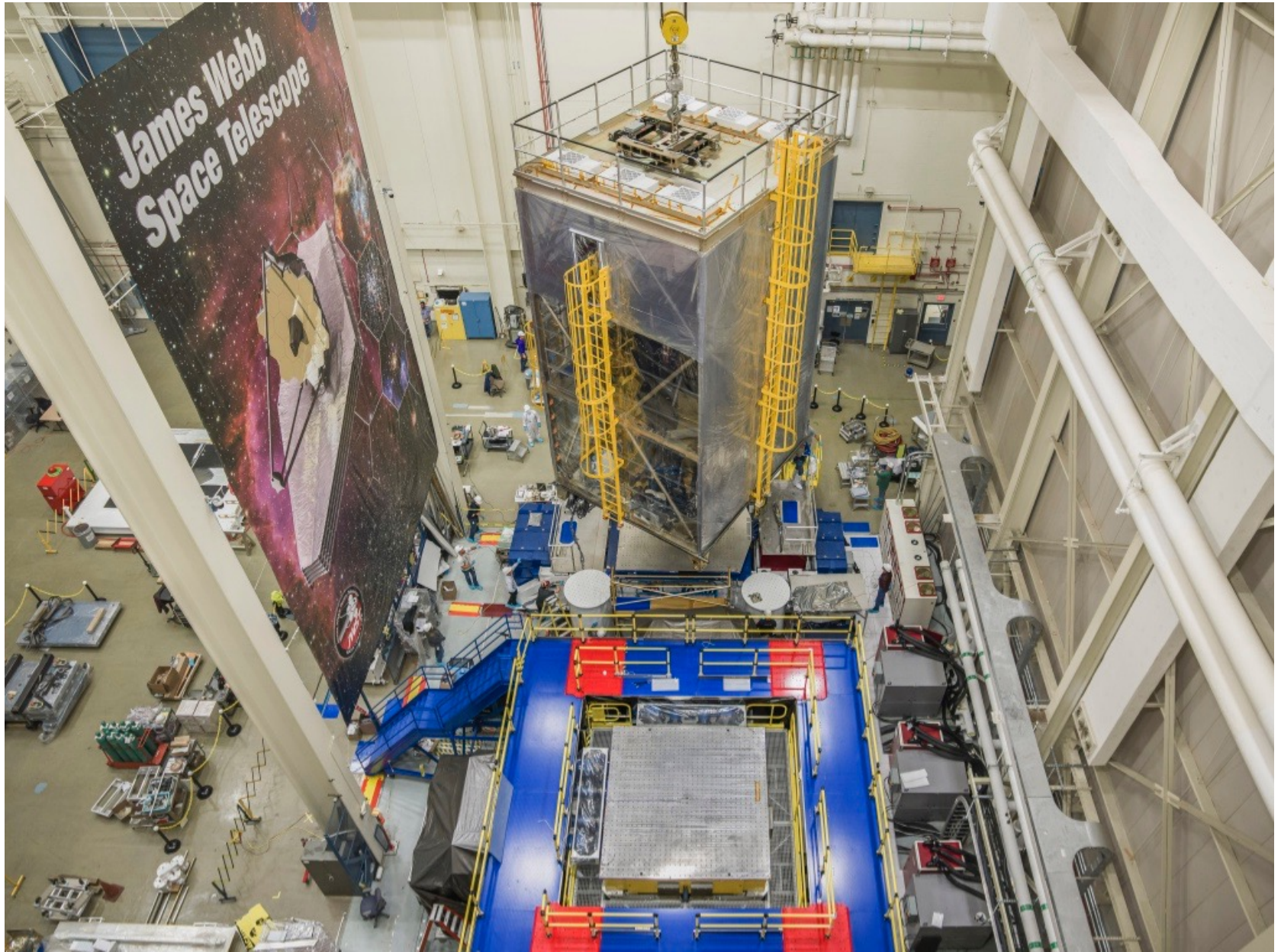
Telescope Primary & Secondary Mirrors



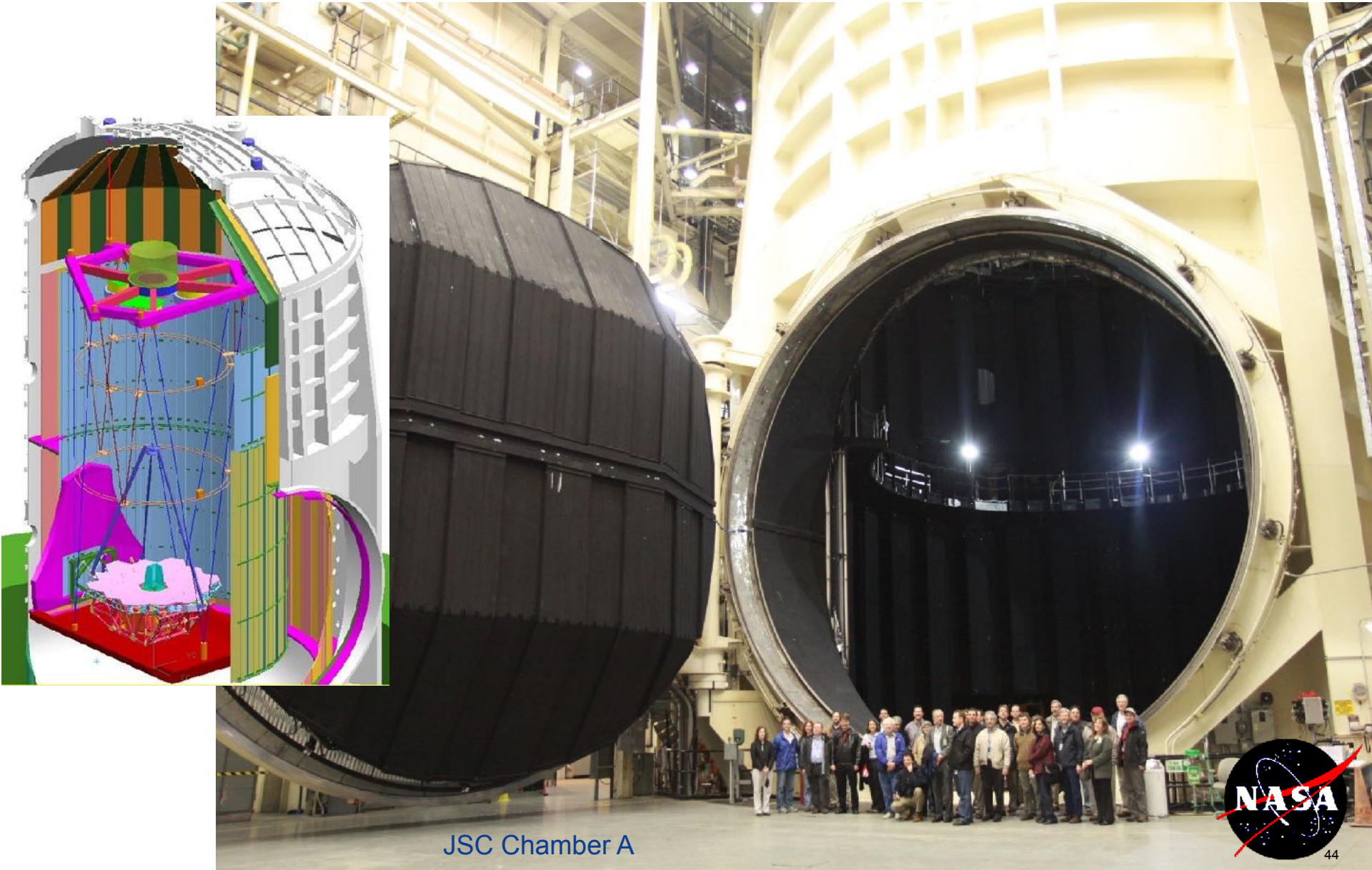
Integrated Telescope



OTIS Preparing for Vibration Testing



OTIS Thermal Vacuum Testing was at the Johnson Space Center in Houston, Texas



JSC Chamber A



Integrated Observatory - Folded Telescope



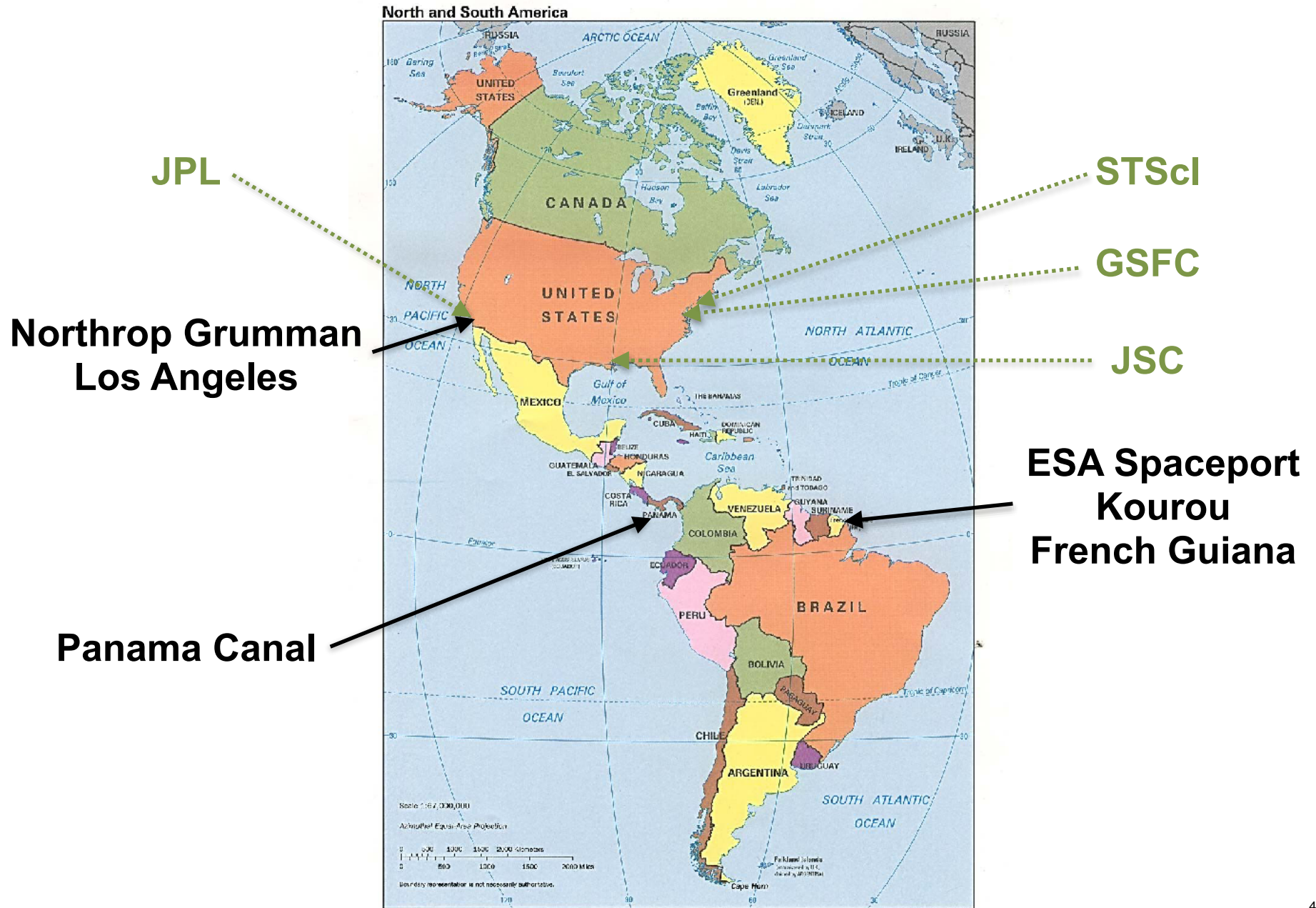
Integrated Observatory - Folded Sunshield



Integrated Observatory - All Folded Up



2021 - From Final Test Site to the Launch Site



European Launch Site - Ariane 5 Rocket



Unloading JWST



Unpacking in the Clean Room



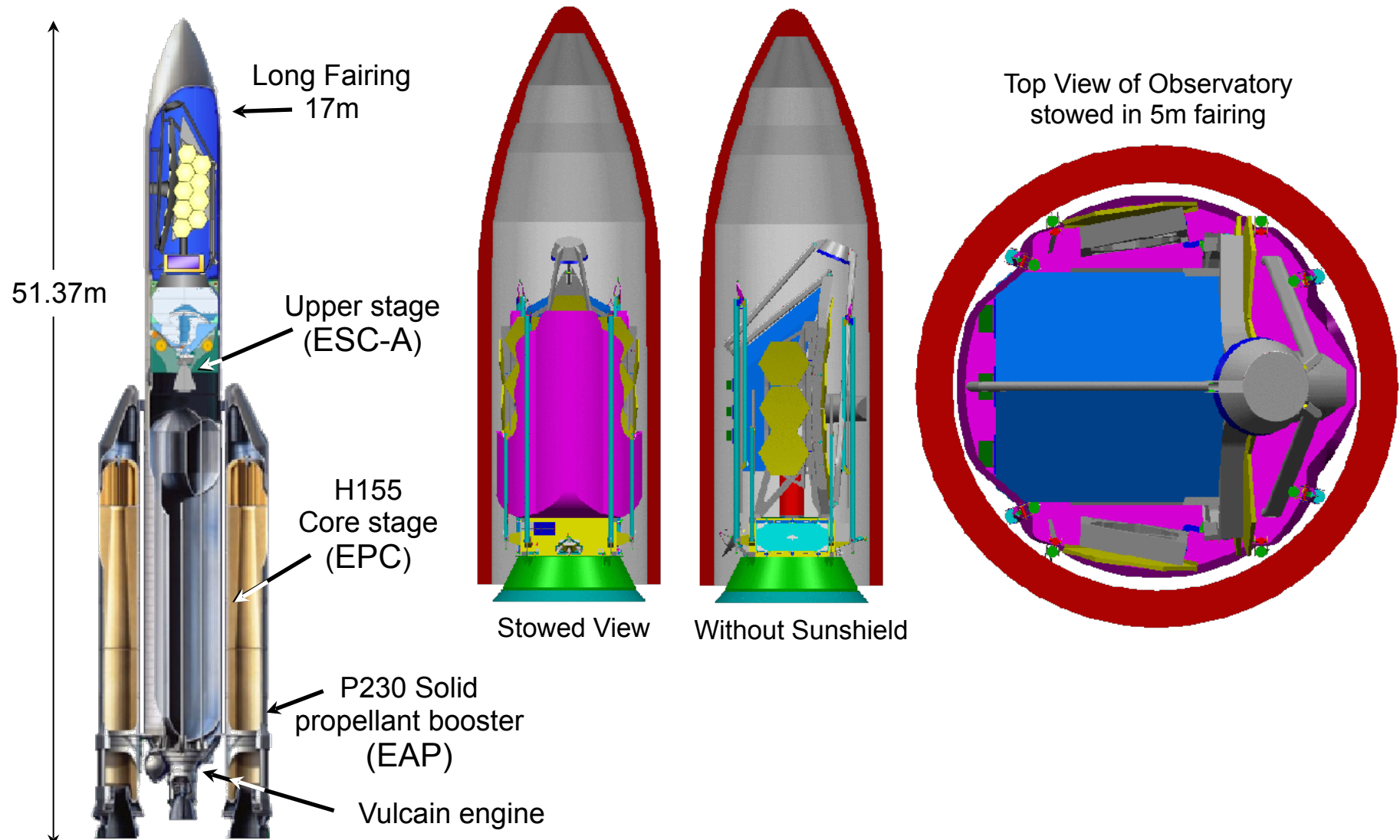
This Way Up!



Ariane 5 Preparations for JWST Launch



Observatory Launch Configuration in Ariane 5



Providing the Ariane 5 Launch is Part of the European Contribution to JWST

- Ariane 5 is one of the world's most reliable heavy lift rockets
- 111 launches since June 1996 and before JWST's successful Christmas Day launch
- 97 consecutive successful launches over the last 19 years
- Mainly used for communications satellite launches where it usually launches two at a time into Geostationary Transfer Orbit with a lift capability of over 11 tonnes
- Ariane 5 has also launched several scientific spacecraft - Herschel and Plank scientific missions to L2 and Rosetta and BepiColombo to Earth-escape orbits
- JWST was launched directly towards L2 and did not go into Earth orbit first
- Ariane 5's job was done after just 27 minutes - it was then another 30 days to get into orbit around L2!

23rd December 2021 Move to the Launch Pad



Finally at the Launch Pad!



25th December 2021 - Launch!

“Lift-off from a tropical rainforest to the edge of time itself” - NASA Commentary



Our Final Sight of JWST (That's Quite Some Gift-Wrapped Christmas Present to the World!)



From Launch to Operations

- From launch to JWST being ready for science operations takes about 6 months
- The first month was needed to get to L2 during which time the Observatory unfolded from the stowed configuration that allowed it to fit inside the launch vehicle and the primary mirror segments were motored forward off their launch stops
- There were 22 major events involving over 180 deployments needed to fully unfold JWST with one really critical period lasting some 11 days - which made the “7 minutes of terror” to put the Perseverance Rover onto Mars look pretty tame!
- The first crucial deployment was of the solar array and communications dish followed by a pause to allow water vapour to outgas before the really critical 11-day period began
- Once in L2 halo orbit, the telescope and instruments have to cool to their supercold operating temperatures and then be focused and calibrated.

The L2 Orbit

- The L2 point and Webb's loose orbit around it are only semi-stable in the radial direction (along the Sun-Earth-L2 line) where there is an equilibrium point at which it would take no thrust to remain in position, however, that point is not stable
- If Webb drifted a little bit toward Earth, it would continue to drift ever closer, if it drifted a little bit away from Earth, it would continue to drift farther away (think hilltop, not valley bottom)
- Webb has thrusters only on the warm, Sun-facing side of the observatory because hot thrusters would contaminate the cold side of the observatory with unwanted heat or with rocket exhaust that could condense on the cold optics
- This means the thrusters can only push Webb away from the Sun, not back toward the Sun (and Earth) and so Webb must always stay on the 'uphill' side of the gravitational potential because if it ever went over the crest and drifted away 'downhill' on the other side there is no ability to come back!

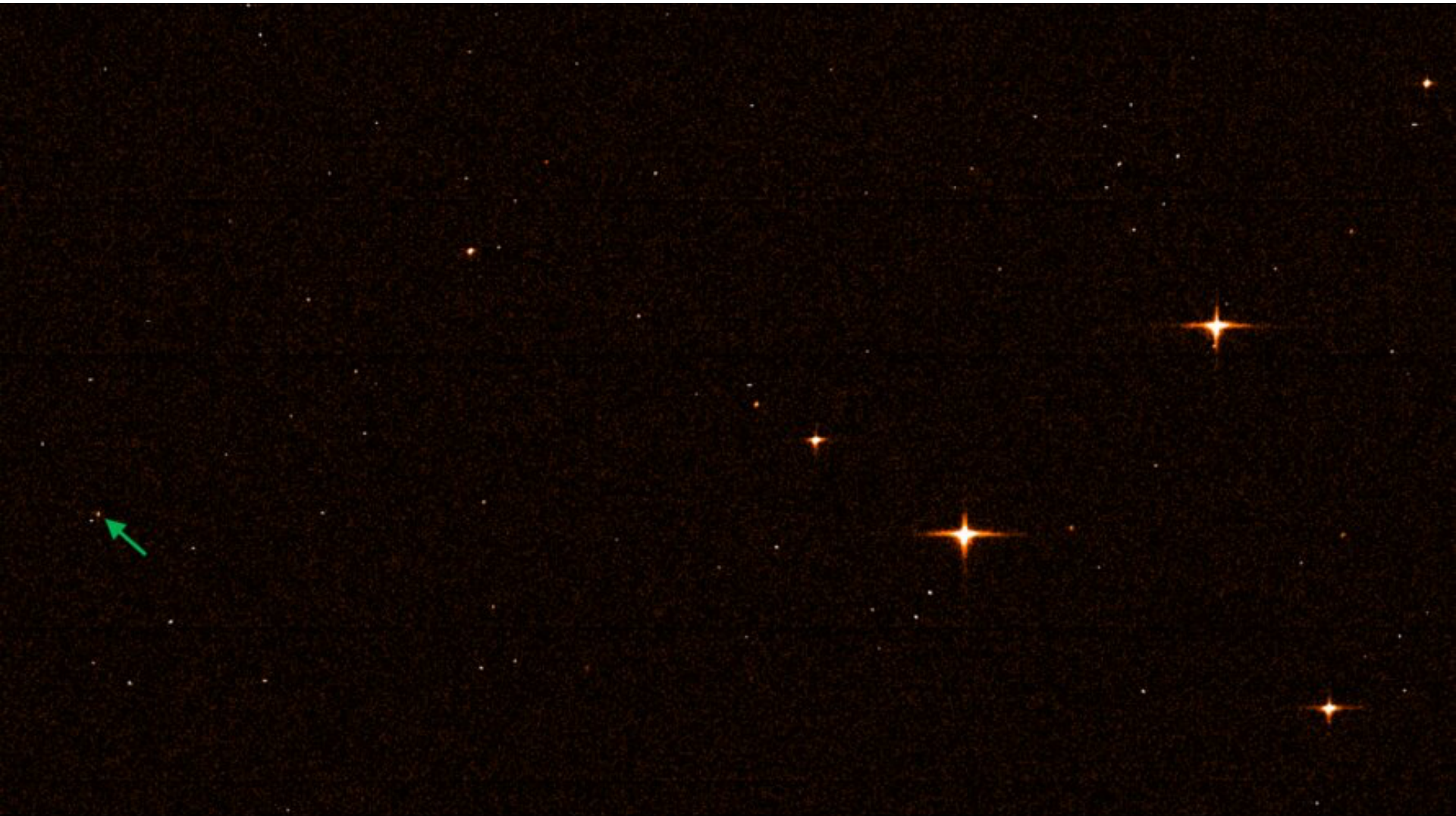
Staying at L2

- The initial L2 'halo' orbit is relatively large at about 400,000 km (or 250,000 miles) from the L2 point - which is a slightly greater radius than the Moon's orbit around the Earth
- As explained in the last slide, the halo orbit is kept on the Sun/Earth side of the actual L2 point so the Observatory would slowly drift back towards the Sun/Earth unless it is periodically nudged back the other way
- This is achieved by making short (approximately 1 minute duration) station keeping burns roughly every 18 to 25 days
- Propellant is also needed to offload the momentum wheels (keep the observatory pointing in a very stable attitude) every so often
- Sufficient propellant was loaded for the 10 year lifetime based on pessimistic assumptions (Ariane 5 accuracy, delayed course correction burns etc) but fuel lifetime has now been almost doubled because Ariane 5's performance was even better than specified and the first mid-course correction burn was on time.

We Can Still See JWST!

- On 18th February, the James Webb Space Telescope was photographed by ESA's Gaia observatory which is also orbiting L2 (Gaia arrived there in 2014)
- When photographed, the two spacecraft were 1 million km apart, with an edge-on view of Gaia towards Webb's huge sunshield but very little reflected sunlight came Gaia's way and Webb therefore appears as a tiny, faint spec of light in Gaia's two telescopes without any details visible
- Although JWST appears as just a dot, it has been positively identified by the mission scientists
- Many amateur astronomers have also tracked and photographed Webb's trail against distant stars
- You might want to consider trying to do this as a challenging project - there's plenty of info on google or at your local astronomy society.

JWST As Seen By Gaia in February



Some Operational Matters

- From days 16 to 25 after launch and whilst heading to L2, the 18 individual main mirror hexagons were very slowly motored forward off their launch stops
- Only after that and when the instrument detectors had cooled sufficiently, could the process to align the 18 primary mirror segments into a single reflecting surface begin
- Once the telescope is aligned, the 4 instruments each have to be checked out and calibrated before the Observatory can be declared commissioned
- All of this has to be achieved remotely - there is no possibility of a human servicing mission
- There was a late proposal to fit a grapple fixture (as used on Hubble) to the Observatory and also to mount cameras to watch deployments, including battery powered cameras on the cold side (where it would be pitch dark!) but these were rejected by the Project as it had significant mass budget problems at the time - optical target features were added to the bus however.

Current Status of Observatory

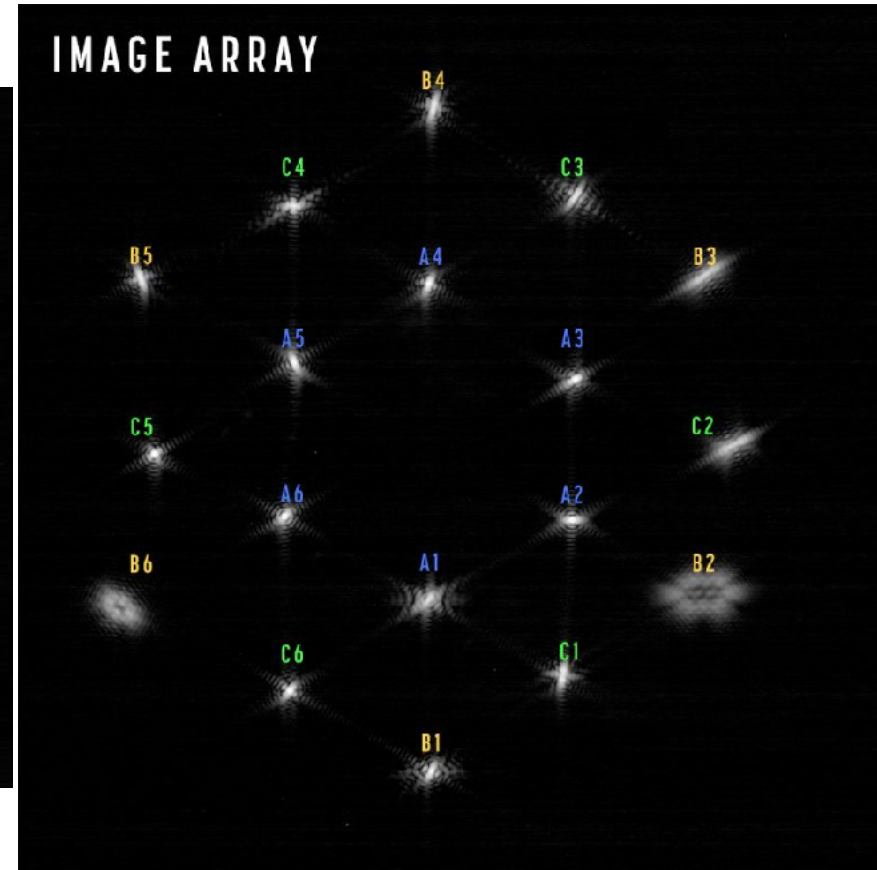
- Webb entered its initial 'halo' orbit around L2 on 24th January this year with a 5 minute thruster burn - now successfully 'on station'
- The Fine Guidance Sensor (part of the Canadian contribution) is now successfully performing its guiding operations - to ensure Webb stays locked onto its celestial targets, this measures the exact position of a guide star in its field of view 16 times per second and sends adjustments to the telescope's fine steering mirror about three times per second
- The telescope and instruments are slowly cooling to their operating temperatures of around 40K (-233C) with the primary mirror segment average temperature currently 43K (-230C) and the 3 near-infrared instruments between 36K and 41K
- The 3 month long process of aligning the 18 primary mirror segments is well underway - now on step 6 of 7 after having moved each of the segments to bring 18 unfocused copies of a single star into a planned hexagonal formation and then stacked the images.

Primary Mirror Alignment Steps 1 and 2

SEGMENT IDENTIFICATION MOSAIC

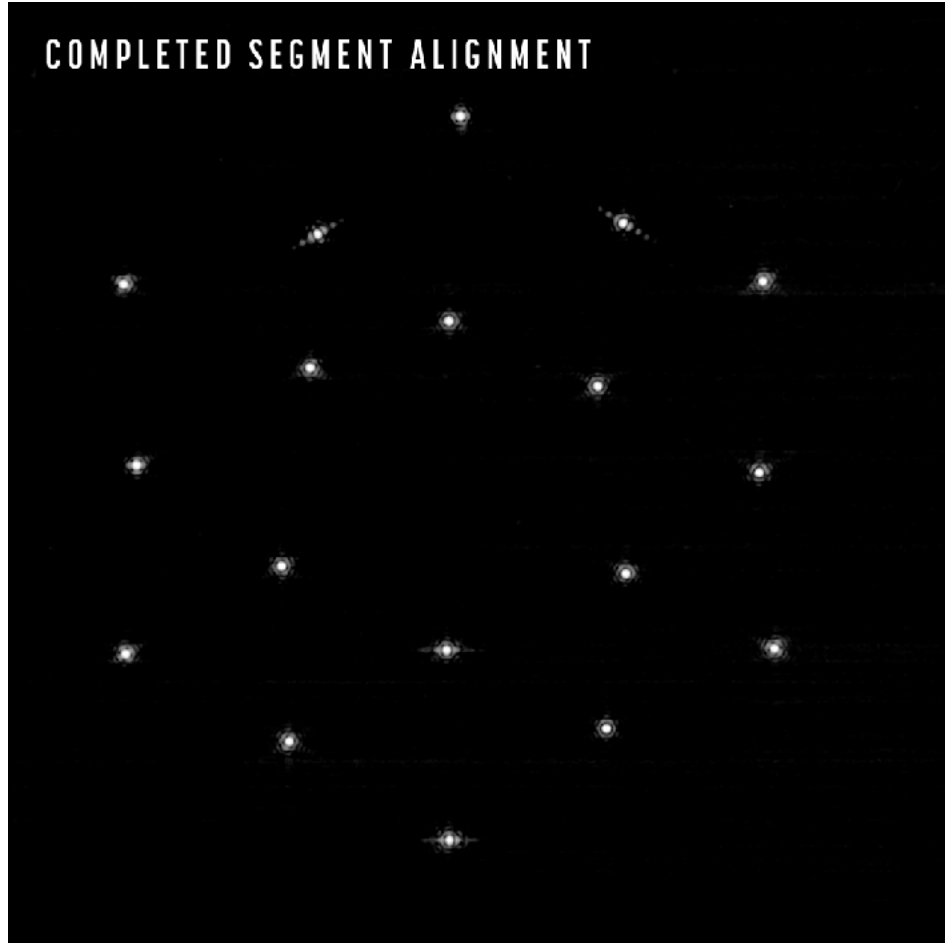


IMAGE ARRAY

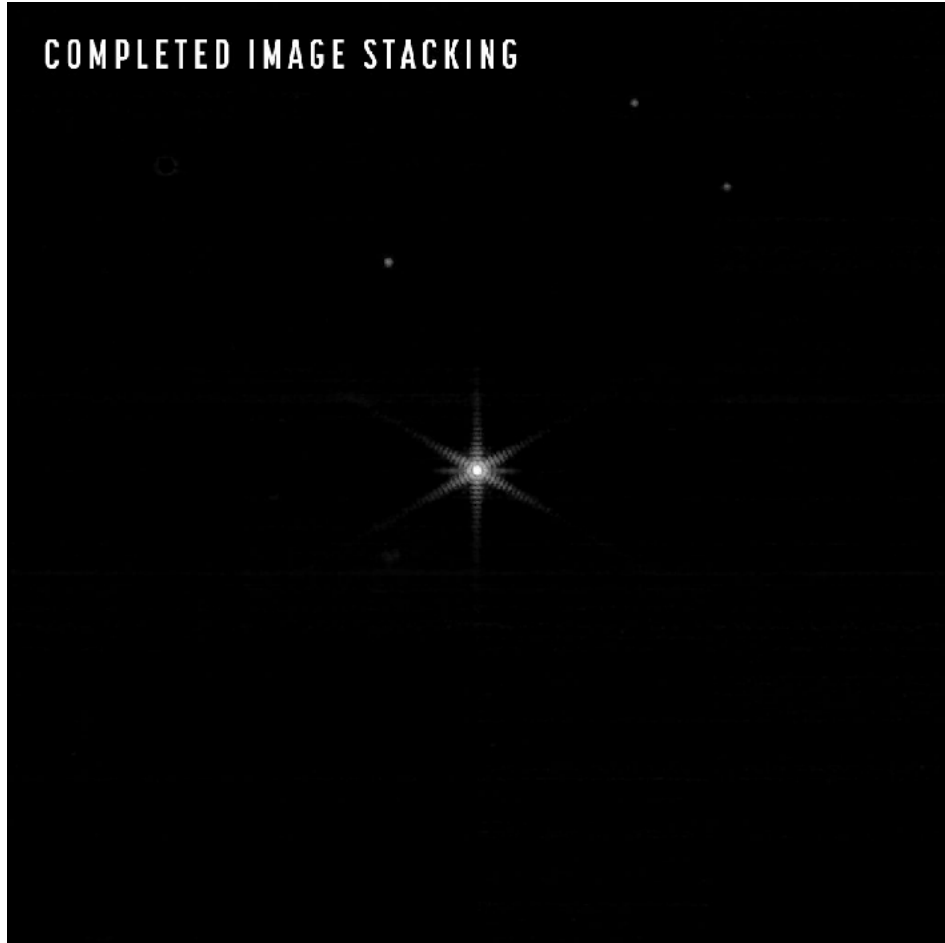


Primary Mirror Alignment Steps 3 and 4

COMPLETED SEGMENT ALIGNMENT



COMPLETED IMAGE STACKING



The single dot of starlight was then made progressively sharper in Step 5

Primary Mirror Alignment Step 5 Completed

TELESCOPE ALIGNMENT EVALUATION IMAGE



Science Operations

- The allocation of 'General Observer Time' for the first observing cycle (approximately one year) amounting to 6000 hours was decided by the Webb Science team in mid-2021
- Future observing cycles will run on approximately a yearly basis
- The proposals from astronomers worldwide for the first year amounted to over 4 times the actual observing time available
- 25% of the ~200 successful proposals involve a UK-based astronomer from almost every UK University with an astronomy department
- MIRI was requested in 40% of these proposals and more scientists from the UK requested observing time than from any other European country
- Cooldown to the 7K operating temperature to enable MIRI observations is expected to be completed around day 96 after launch (although telescope alignment will still be underway).

What Will We See?

- First images will depend on when the Observatory is ready to operate because only a certain swath of sky (~35%) can be observed on any particular date due to the need to keep the telescope and instruments behind the sunshield - but over a year the entire sky is visible (& list of first image candidates is secret!)
- The Observatory can rotate 360° around the line from the Sun & tilt to point the telescope within a 50° arc whilst still keeping the telescope & instruments safely in the shadow of the sunshield
- The first calibrated images are expected to be released around June 2022 if all goes as planned but some test images may well be released earlier
- Images will be in false colour, probably using the Hubble palette, but should look much fuller & denser than Hubble images and be 3 times sharper (at 1 micron wavelength)
- Images should be 'Mind Blowing' according to ESA's Science Director - and we will be looking into unexplored territory at light that has never been detected by humans before.

Hubble Images in Visible and Near-IR



Finally - What Does It Mean?

- **We will literally see our deep universe in a whole new light!**
- The leader article in 'The Times' newspaper on 27th December 2021 included the following thoughts:
- **James Webb should reveal things never known before to man. It will be able to see so far away that it will pick up light travelling from the time when the galaxies were born. This could tell us how the pioneer stars ended the darkness thought to have gripped the cosmos shortly after the Big Bang, more than 13.5 billion years ago.**
- **There is something metaphysical about such astronomic physics. Touching the edge of the universe and the creation of the world we know has been a core religious and scientific quest of all humankind.**
- **James Webb may even search for other civilisations. It will tell us much about our own.**